

# AIR75-2100B Operation Manual

V1.0.1

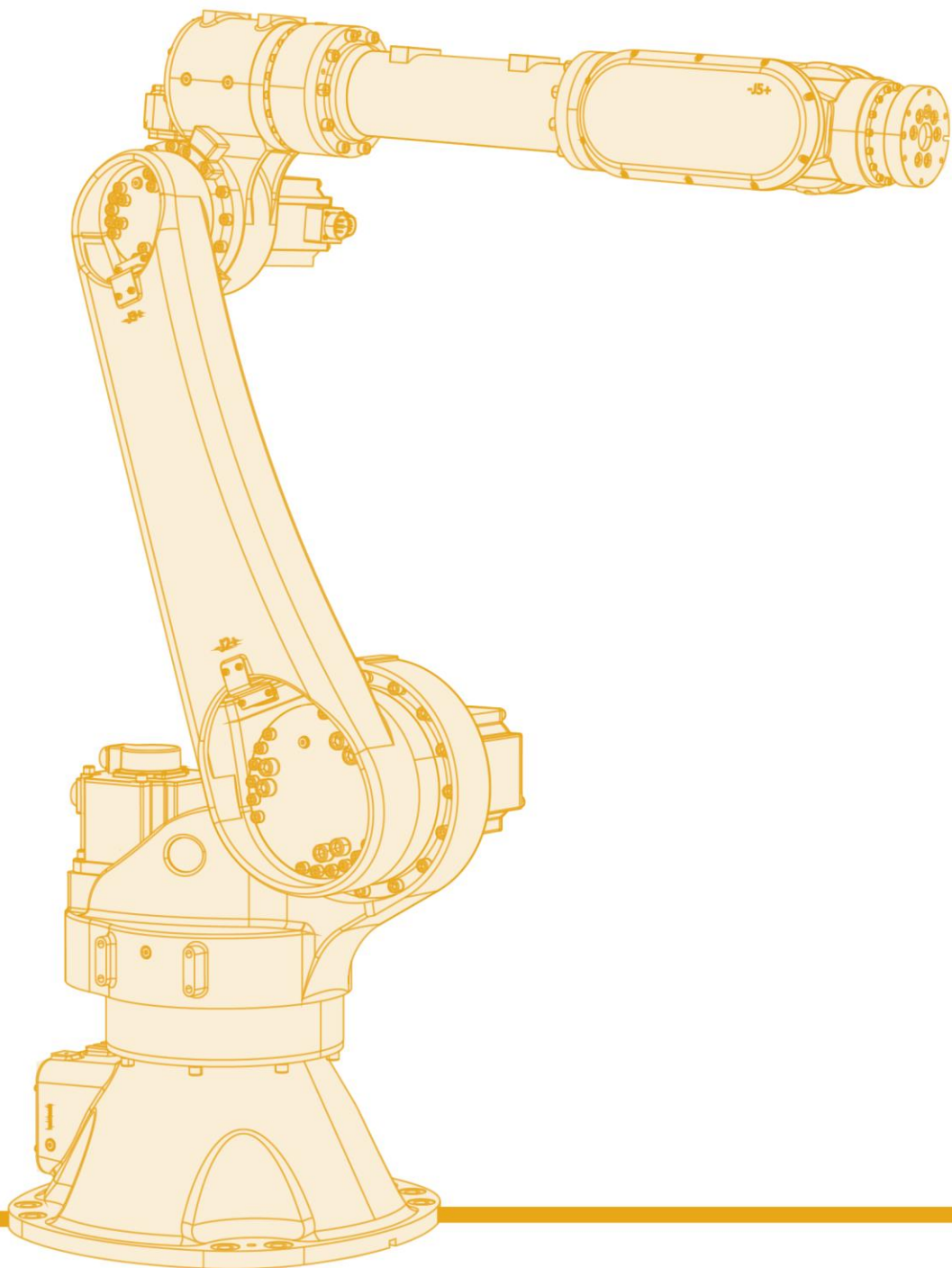



# Foreword

---

## About this manual

This manual is for technicians to install, use, and use the AIR75-2100B industrial robot quickly, correctly, and safely, to be familiar with the relevant precautions, and to perform regular routine maintenance work on the manipulator.

## Prerequisites

Before operating the robot, be sure to read the relevant safety instructions and operation instructions of the product carefully. Users must understand the safety knowledge and basic operation knowledge before using the robot.

Please read the following documents when necessary:

- ARC4-50/ARC4-75 Control Cabinet Manual
- AIR-TP Teaching pendant operation manual
- ARL Programming Manual
- AIR Series Industrial Robot System Fault and Handling Manual



## Target groups



- Operators
- Product technicians
- Technical service personnel
- Robot teachers

## Meaning of common signs

The signs and their meanings in this manual are detailed in Table 1.

Table 1 Signs used in this manual

Sign	Meaning
 Danger	Failure to follow the instructions may result in an accident causing the severe or fatal injury or the great losses of property.
 Warning	Failure to follow the instructions may result in an accident causing the severe or fatal injury or the great losses of property.

Sign	Meaning
 Caution	Prompt for the environmental conditions and important things or shortcuts you shall pay attention to
 Prompt	Prompt for additional literature and instructions for additional information or more detailed operating instructions

### Manual description

The contents of this manual are subject to supplementation and modification. Please visit "Download Center" on the website regularly to obtain the latest version of this manual in a timely manner.

Website URL: <http://robot.peitian.com/>

### Revision history

The revision history contains the instructions for each document update. The latest version of the document contains updates to all previous versions of the document.

Table 2 Signs used in this manual

Version	Publication date	Modification description
V1.0.0	2023.03.17	1st official publication
V1.0.1	2023.09.14	2nd official release Fix known bugs

### Manual Number and Version

The manual-related information is shown in Table 3.

Table 3 Document-related information

Document name	"AIR75-2100B Operation Manual"
Document number	UM-P05310000103-001
Document version	V1.0.1

### Declaration of applicable with product standards

The requirements for industrial robot system design are detailed in Table 4.

Table 4 Declaration of applicable safety standards

Standard	Description	Version
2006/42/EC	Machinery directive : Machinery directive 2006/42/EC (new version) issued by European Parliament and Council on May 17, 2006 to modify 95/16/EC	2006
2014/30/EU	Electromagnetic compatibility directive: 2014/30/EU directive issued by European Parliament and Council on February 26, 2014 to balance the electromagnetic compatibility regulations of member states	2014
2014/68/EU	Pressure facility directive: Electromagnetic compatibility directive: 2014/68/EU directive issued by European Parliament and Council on May 15, 2014 to balance the pressure facility regulations of member states (It is only suitable for the robot with hydraulic balance weight)	2014
ISO 13850	Safety of machinery: Emergency stop function - Principles for design	2015
ISO 13849-1	Safety of machinery: Safety-related parts of control systems - Part 1: General principles for design	2015
ISO 12100	Safety of machinery: General principles for design - Risk assessment and risk reduction	2010
ISO 10218-1	Robots and robotic devices - Safety requirements for industrial robots : Part 1: Robots (Prompt: Information is consistent with ANSI/RIAR.15.06-2012, Part 1)	2011
61000-6-2	Electromagnetic compatibility (EMC): Part 6-2: Generic standards - Immunity for industrial environments	2005
61000-6-4 + A1	Electromagnetic compatibility (EMC): Part 6-4: Generic standards - Emission standard for industrial environments	2011
60204-1 + A1	Safety of machinery: Electrical equipment of machines - Part 1: General requirements	2009
IEC 60529	IP rating provided by enclosures (IP Code): This standard applies to the IP rating for the electrical equipment with enclosures and the rated voltage exceeding 72.5kv.	2001



## General safety description

---

Thank you for purchasing our manipulator. This description is required for the safe use of the manipulator. before using the operator, please read the manual carefully and use the manipulator correctly on the premise of understanding it.

For the detailed functions of the manipulator, please fully understand its specifications through the relevant instructions.

### Safety considerations

In general, the manipulator cannot be operated by a single operation, and only install the end effector, and the frame functions as the peripheral equipment and the system to perform the operation.

When considering its security, the manipulator should not be considered independently, but should be considered in the system environment.

#### WARNING, CAUTION AND PROMPTS.

This specification includes matters needing attention to ensure the personal safety of operators and prevent damage to operators. According to their safety importance, they are described as "warning" and "caution" in this paper, and the supplementary instructions are described as "prompts".

Before using the operator, the user must read these "warnings "," cautions" and "prompts ".



Warning

In the case of an incorrect operation, it is possible to cause death or serious injury to the operator or other operator.



Caution

If the operation is wrong, it may cause the operator or other operator to slightly injure or damage the equipment.

### General considerations



Warning

When connecting or disconnecting related peripheral equipment and various signals of the operating machine, be sure to confirm that the manipulator is in a stopped state to avoid wrong connection.

Operators who use the operator should wear the safety appliances shown below before carrying out their work.

- Work clothes suitable for the job content
- Safety shoes
- Safety helmet



Prompt

Personnel who carry out programming and maintenance operations must receive appropriate training through the relevant training of the company.

Considerations during installation



Warning

- When handling and installing the machines, they must be carried out correctly according to the method shown in our manual. If the operation is carried out in the wrong way, it is possible that the operator will be killed or injured due to the overturning of the operator.
- When using the operator for the first time after installation, be sure to do so at a low speed, and then gradually accelerate the speed and confirm that there are any anomalies.

Matters needing attention in operation



Warning

- When using the operator, be sure to make sure there are no personnel in the safety fence before carrying out the operation. At the same time, check to see if there is a potential danger, and when it is confirmed that there is a potential danger, be sure to eliminate the danger before carrying out the operation.
- When using the instruction device, because there may be errors in the operation of wearing gloves, it is important to take off the gloves before carrying out the work.



Prompt

Information such as programs and system variables can be stored in storage media such as memory cards. In order to prevent data loss caused by unexpected accidents, it is recommended that users back up data regularly.



# Contents

Foreword.....	I
General safety description .....	V
Contents .....	i
1. Product specification .....	1
1.1. General functions and intended applications .....	1
1.2. Environmental conditions and working and storage limitations .....	1
1.2.1. <i>Environmental requirements</i> .....	1
1.2.2. <i>Environmental conditions for long-term storage</i> .....	2
1.2.3. <i>Precautions for storage</i> .....	2
1.3. Basic specifications.....	2
2. Robot system introduction .....	5
2.1. Introduction to industrial robots .....	5
2.2. Basic configuration of manipulator .....	5
2.3. Product label and meaning .....	6
3. Preparation before use.....	11
3.1. Safety precautions before use .....	11
3.2. Product unpacking .....	13
3.2.1. <i>Unpacking method</i> .....	13
3.2.2. <i>Repackaging to prevent transportation damage</i> .....	13
3.2.3. <i>Safe disposal of packaging materials</i> .....	14
3.2.4. <i>Disposal of waste materials</i> .....	14
3.3. Preparation before installation.....	14
3.3.1. <i>Installation Precautions</i> .....	14
3.3.2. <i>Installation tools and required connectors</i> .....	14
3.4. Installation and assembly.....	14
3.4.1. <i>Technical specifications</i> .....	15
3.4.2. <i>Fixed way</i> .....	15
4. Electrical interface .....	19
4.1. Manipulator electrical interface type.....	19
4.2. Heavy-load line interface on the manipulator side .....	19
5. Adaptation and connection of products with other devices .....	23
5.1. Connection between manipulator and control cabinet.....	23
5.2. Manipulator and power supply connection .....	24
5.3. Connection of manipulator and accessories .....	26
5.4. Examples of attachment types.....	26
6. Job description .....	29
6.1. Safe operation .....	29
6.1.1. <i>Dimensions and working range of each axis</i> .....	29
6.1.2. <i>Mechanical limit</i> .....	30
6.1.3. <i>Stopping method</i> .....	30
6.2. Calibration .....	31
6.2.1. <i>When calibration is required</i> .....	31
6.2.2. <i>Calibration position of each axis</i> .....	31
6.2.3. <i>Movement direction of each axis</i> .....	33
6.2.4. <i>Speed of each axis</i> .....	34
6.3. Output flange size .....	34
6.4. Load and installation method.....	35
7. Transportation and handling .....	41
7.1. Transport attitude.....	41
7.2. Transport dimensions.....	42
7.3. Handling method.....	43

---

8.	General principles of maintenance.....	45
9.	Preventive maintenance.....	46
9.1.	Safety protection measures .....	46
9.2.	Daily maintenance.....	47
9.3.	First maintenance.....	47
9.4.	Regular maintenance .....	49
10.	Project maintenance process.....	51
10.1.	Cleaning the manipulator.....	51
10.2.	Check and repair cables .....	51
10.3.	Replacing the battery .....	54
10.4.	Replace the lubricating grease.....	55
10.5.	Replace timing belt .....	61
11.	Fault finding, diagnosis and repair .....	65
	Appendix A AIR75-2100B type manipulator regular maintenance table.....	73
	Appendix B Table of screw strength and tightening torque (Nm).....	77

# 1. Product specification

## 1.1. General functions and intended applications

Industrial robot systems are used to move tools and devices, or process and transport workpieces or products. It is allowed to be used only in accordance with the specified climatic and environmental conditions. For specific storage conditions and working environment requirements, please refer to *Chapter 1.2*.

All non-compliant use is illegal and prohibited. These non-compliant uses include:

- Use in environments where there is a danger of explosion.
- Use outside the allowed motion range.
- Transporting people or animals.
- Used as a climbing aid.



Caution

Changing the structure of the robot, such as drilling holes, can cause component damage. This is regarded as improper use and will result in loss of warranty and claim eligibility.

## 1.2. Environmental conditions and working and storage limitations

### 1.2.1. Environmental requirements

See Table 1-1 for the operating environment requirements of AIR75-2100B manipulator.

Table 1-1 Environmental requirements for AIR75-2100B equipment manipulator

Parameter	Value	
Temperature	Lowest temperature	0°C
	Maximum temperature	45°C
Humidity	The operating environment requirements of the manipulator do not exceed the humidity level not higher than 95% as specified in the document "IEC 60721-3-3-2002 Classification of environmental conditions".	
Altitude	The altitude of the normal operating environment of the manipulator should not exceed 1000m. In the height range of 1000m-4000m, the manipulator should be reduced in rated power to use	
Shock resistance	The robot manipulator should be used in an environment without vibration as much as possible. The environmental vibration limit frequency is 5Hz~55Hz, and the amplitude does not exceed 0.15mm.	
Special environmental requirements	The manipulator is prohibited to use in flammable, explosive and corrosive environment.	



Caution

When the ambient temperature is below 10°C, it is recommended to warm up the machine for a few minutes before use to prevent changes in the viscosity of the lubricating grease from causing robot alarms or performance degradation.

### 1.2.2. Environmental conditions for long-term storage

Please refer to Table 1-2 for the long-term storage environment conditions of the AIR75-2100B operating machine.

Table 1-2 Manipulator long-term storage environmental conditions

Parameter	Value
Minimum ambient temperature	-25°C
Maximum ambient temperature	55°C
Maximum ambient temperature (storage time less than 24h)	70°C
Maximum ambient humidity	Less than 95% at constant temperature, no condensation
Maximum vibration conditions	Frequency 22Hz, amplitude 0.15mm

### 1.2.3. Precautions for storage

In addition to the content of *Chapter 1.2.1* of this manual, the long-term storage of the manipulator should also pay attention to the following items:

- Before long-term storage of the manipulator, the posture should be in the transport posture, placed on a horizontal surface and fixed, see *Chapter 3.3* of this manual for details.
- When the manipulator is not used for a long time, all power supply should be cut off.
- Use an outer protective cover such as paper or wooden packaging box to protect the manipulator from external light to avoid long-term exposure to the manipulator or exposure to water, oil, corrosive liquids, etc.
- The surface of the manipulator should be cleaned regularly, such as dust removal and decontamination. The specific cleaning cycle depends on the storage environment of the manipulator.
- When the storage period ends and the manipulator is put back into use, the manipulator must be inspected in accordance with *Chapter 3.3.1* of this manual.

## 1.3. Basic specifications

The basic specifications of AIR75-2100B robot are shown in Table 1-3.

Table 1-3 Basic specifications of AIR75-2100B robot

Parameter	Value	
Coordinate form	Horizontal multiple joint robot	
Number of control axes	6 axes(J1,J2,J3,J4,J5,J6)	
Action range (upper/lower limit)	J1	-185°~185°
	J2	-75°~145°
	J3	-120°~170°
	J4	-350°~350°
	J5	-120°~120°
	J6	Unlimited
Maximum range of motion	750mm	

Parameter		Value
Maximum operating speed	J1	177°/s
	J2	178°/s
	J3	173°/s
	J4	260°/s
	J5	255°/s
	J6	350°/s
Handling weight	Wrist	75kg
	Elbow	20kg
Drive method		Use AC servo motor for electric servo drive
Repeatability		± 0.06mm
Robot quality		530kg
Noise		70dB
IP protection level		IP54 (Wrist IP67)
Installation conditions		<ul style="list-style-type: none"> <li>■ Ambient temperature: 0°C~45°C</li> <li>■ Humidity: within 95% at constant temperature, no condensation</li> <li>■ Allowable height: below 1000m above sea level</li> <li>■ There should be no corrosive, flammable, explosive gases</li> </ul>



## 2. Robot system introduction

---

### 2.1. Introduction to industrial robots

The industrial robot system is mainly composed of three basic parts: industrial robot manipulator, control cabinet and teach pendant:

- Manipulator refers to the mechanism used to grab or move objects (tools or workpieces) in the robot system, also known as the robot body. This manipulator is a horizontal multi-joint industrial robot, including a linear axis and three rotary axes.
- Control cabinet is installed with the electrical equipment needed to control the robot, and provides a connection interface with the robot manipulator and other external equipment.
- Teach pendant is connected to the main control system of the control cabinet, and is used to control the manual/automatic operation of the robot, record the running track, display playback or record the teaching point and program according to the teaching point.

The structure of AIR75-2100B horizontal multi-joint industrial robot system is shown in Figure 2-1.

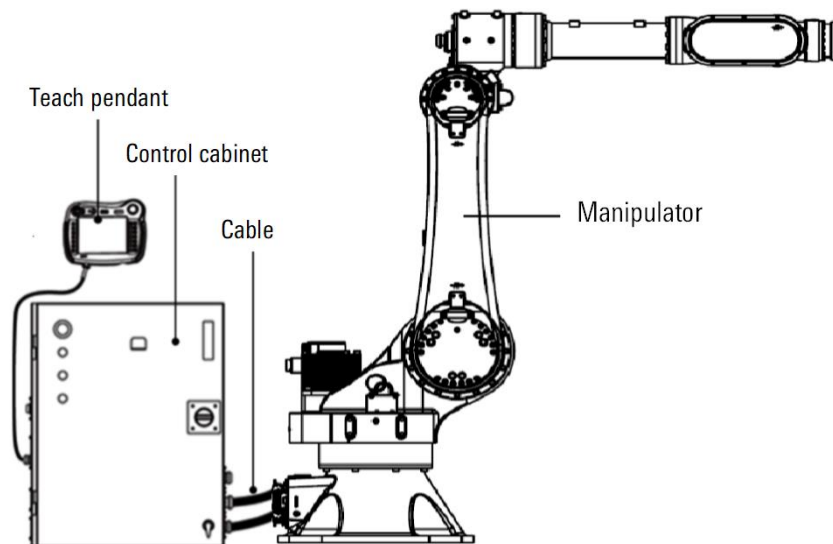

Figure 2-1 Composition of AIR75-2100B industrial robot system

### 2.2. Basic configuration of manipulator

The names of AIR75-2100B type manipulator and each part of it are shown in Figure 2-2.

For the basic specifications of the AIR75-2100B manipulator, please refer to *Chapter 1.3* of this manual. For the dimensions and working range of each axis, please refer to "6.1.1 Dimensions and working range of each axis".

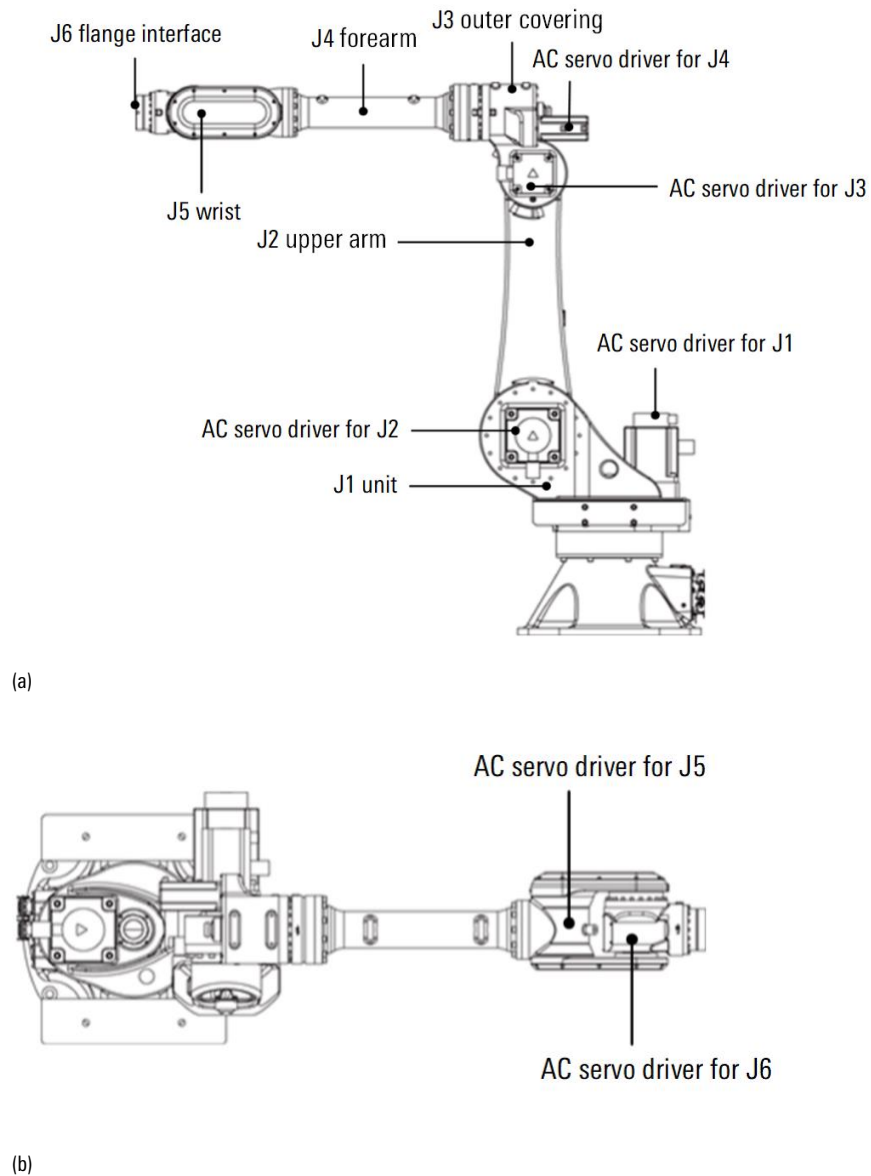

Figure 2-2 AIR75-2100B manipulator and its parts

### 2.3. Product label and meaning

#### Manipulator nameplate

The nameplate of the AIR75-2100B manipulator is attached to the base. The nameplate contains the corresponding model, product number, weight, serial number, production date and other information of the corresponding product (refer to Figure 2-3).



 配天机器人技术有限公司 Peitian Robotics Technology Co., Ltd.	
型号	Type
产品号	Product No.
序列号	Serial No.
生产日期	Date
重量	Weight
负载	Load
运动半径	Range

Figure 2-3 Diagram of the nameplate of the AIR75-2100B manipulator

### No approaching label

There is a prominent 'No Approaching' label affixed to the back of the manipulator's upper arm (as shown in Figure 2-4), with the label position referenced in Figure 2-7.



Figure 2-4 No approaching label

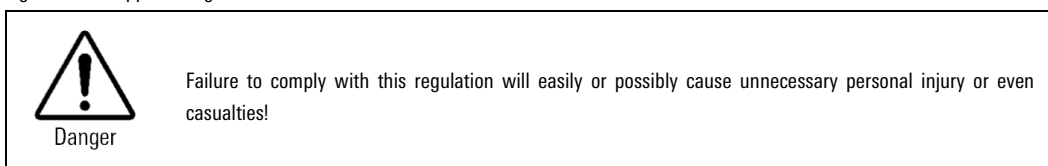

### Transportation posture label

The transportation posture label of each axis of the AIR75-2100B is affixed to the base of the manipulator (as shown in Figure 2-5). Please refer to Figure 2-7 for the label location.

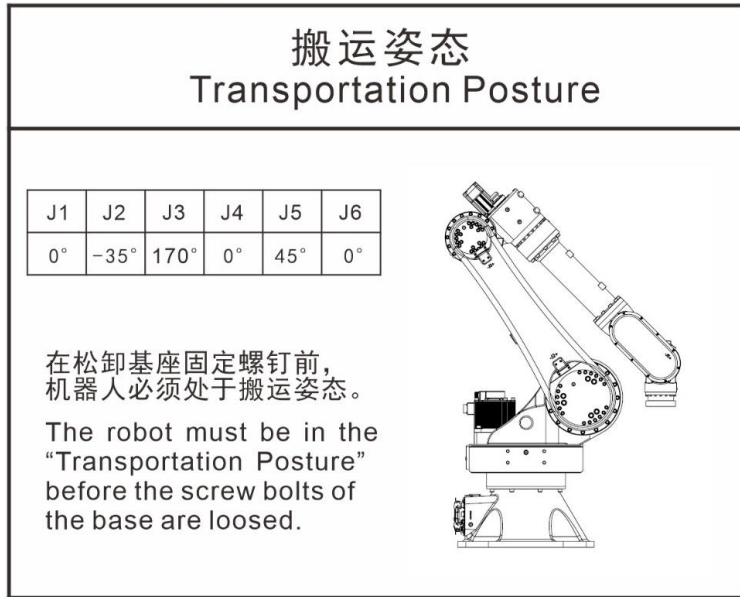

Figure 2-5 Transportation posture label

### No trampling label

There is a no trampling label attached to the shoulder of the manipulator (as shown in Figure 2-6). Please refer to Figure 2-7 for the location of the label.



Figure 2-6 No trampling label

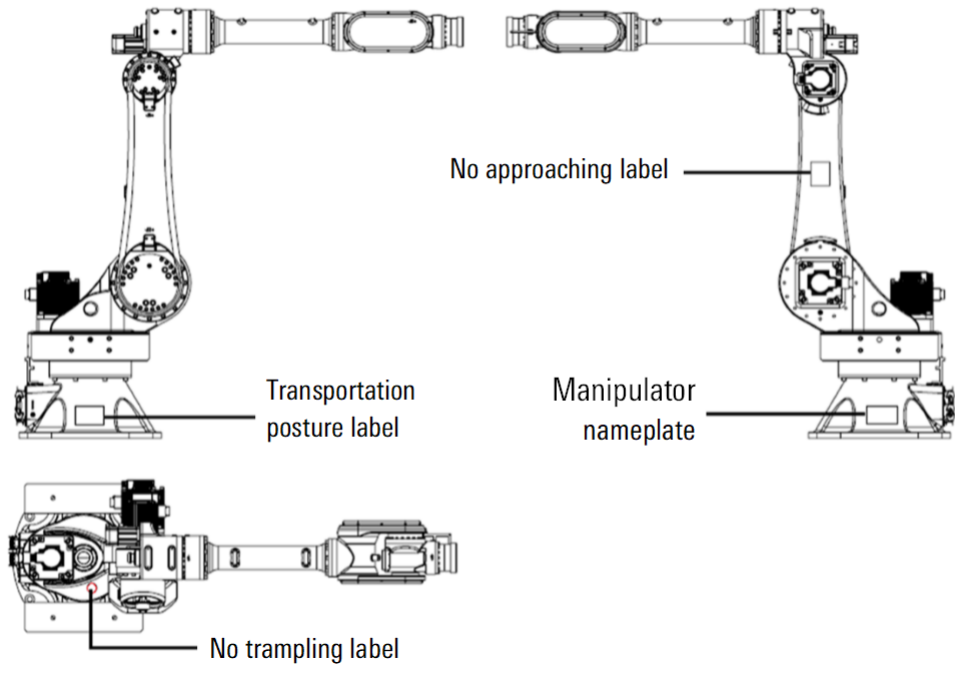

Figure 2-7 Label location illustration



## 3. Preparation before use

---

### 3.1. Safety precautions before use

Before operating the manipulator, peripheral equipment and manipulator system, the safety precautions of the operator and the system must be fully studied.

Figure 3-1 is a diagram of the safe working of the AIR75-2100B industrial robot.

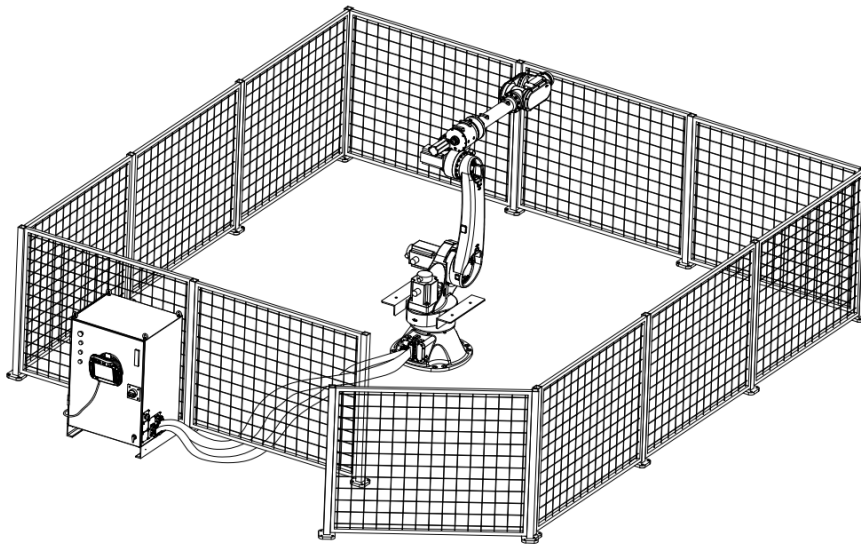

Figure 3-1 Diagram of safe working of industrial robots

#### Operator definition

The operators of the manipulator are mainly divided into three types: operators, teachers, and maintenance engineers. The conditions that these three operators need to meet are described as follows:

##### Operators

- ON/OFF operation of the power supply of the manipulator;
- Start the manipulator program through the operation panel;

##### Teachers

- Possess the function of operator;

##### Maintenance engineers

- Possess the function of teacher;
- Can carry out maintenance (repair, adjustment, replacement, etc.) operation of the manipulator.

#### Operator safety

When operating, programming, and maintaining the manipulator, operators, teachers, and maintenance engineers must pay attention to safety, and at least wear the following items for work:

- Work clothes suitable for the content of the job
- Safety shoes

- Helmet

When using an automatic system, you must try to ensure the safety of the operators. It is very dangerous to enter the operating range of the manipulator. Measures should be taken to prevent the operators from entering the operating range of the manipulator.

The general precautions are listed below, please take appropriate measures to ensure the safety of the operators:

- The operation personnel running the manipulator system shall receive the training from the company and pass the relevant assessment.
- While the equipment is running, even if the manipulator seems to have stopped, the manipulator is possibly waiting for the start signal and is about to act. The manipulator shall be regarded as operating at this state. To ensure the safety of operation personnel, it is necessary to confirm that the manipulator is in the operating state via the audible and visual alarms such as the warning lamp
- Peripheral equipment shall be electrically grounded.
- The peripheral equipment shall be set outside the range of manipulator if possible.
- The range of manipulator shall be clearly marked with the lines on the floor to make the operator understand the range of manipulator including the mechanical arm and other tools.
- A proximity switch or photoelectric switch shall be installed on the floor so that when the operation personnel are about to enter the range of manipulator, the audible and visual alarms such as the buzzer are issued to stop the manipulator, thereby ensuring the safety of operation personnel.
- A lock shall be set if it is possible to make sure that the manipulator power cannot be turned on except by the operation personnel responsible for the operation.
- Always disconnect the manipulator power when performing the individual commissioning of peripheral equipment.

## Safety of Operators

The emergency stop button should be set within the reach of the operators.



Prompt

Manipulator controller is designed to be connected to an external emergency stop button. With this connection, the manipulator will stop when the external emergency stop button is pressed.

## Safety of Teachers

In the teaching operation of the manipulator, in some cases, it is necessary to enter the working range of the manipulator, in this case, special attention should be paid to safety:

- If you do not need to enter the manipulator range, be sure to operate outside the manipulator range.
- Before proceeding with the teaching, verify that the manipulator or peripheral equipment is in a safe state.
- If it is inevitable to enter the range of manipulator to conduct the teaching, first confirm the positions and states of safety devices (such as the emergency stop button, emergency automatic stop switch of teach pendant, etc.).
- Teachers shall pay special attention to make other people away from the range of manipulator.
- Before starting the manipulator, first confirm that there is no people and no abnormality in the range of manipulator.
- After the teaching is over, be sure to perform the test run following the steps below:
  - Step1. At low speed, execute at least one cycle intermittently to confirm no abnormality.
  - Step2. At low speed, execute at least one cycle continuously to confirm no abnormality
  - Step3. At intermediate speed, execute at least one cycle continuously to confirm no abnormality
  - Step4. At operating speed, execute at least one cycle continuously to confirm no abnormality

Step5. Execute the program in automatic operation mode.

## 3.2. Product unpacking

### 3.2.1. Unpacking method

As shown in Figure 3-2 the packaging box of the AIR75-2100B manipulator is composed of a box body and a bottom bracket.

Operation process of unpacking:

- Step1. Use a wrench to unscrew the screws, washers and nuts connecting the cabinet and the base to separate the cabinet and the base.
- Step2. Open the packaging bag of the wrapping machine and take out the built-in calcium chloride desiccant.
- Step3. Use an allen wrench to unscrew the 5 M10 and 4 M5 hexagonal cylindrical head screws, washers and nuts that connect the manipulator, the end support and the bottom bracket, and you can separate the manipulator from the bottom bracket and the end support. Due to loose screws during disassembly, please be careful not to tilt the manipulator and prevent it from tipping over.

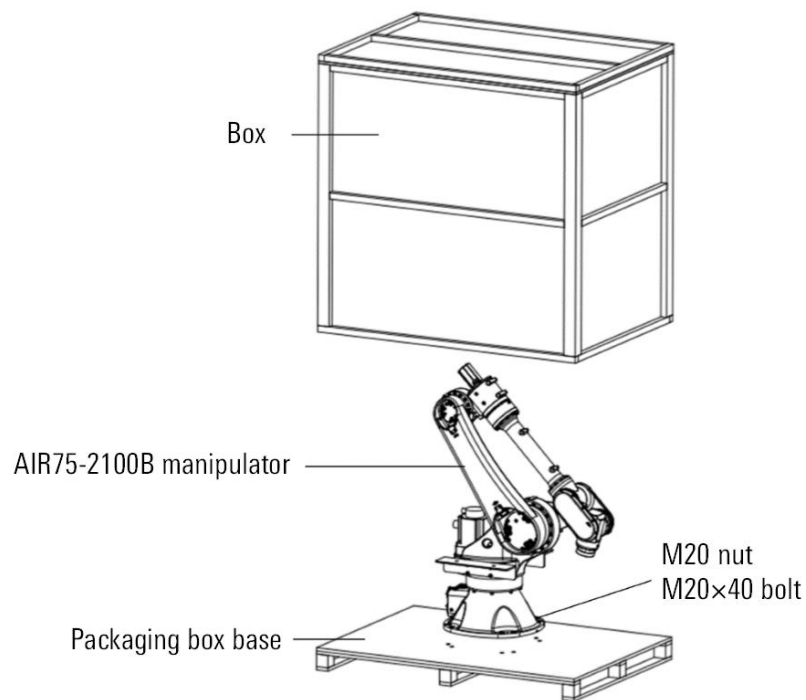

Figure 3-2 Composition of the AIR75-2100B manipulator packaging box

### 3.2.2. Repackaging to prevent transportation damage

Repackaging operation process below:

- Step1. In order to facilitate re-transportation, the repackaging should use the box, bottom bracket, end support and fasteners of the first packaging. In order to avoid the manipulator from getting damp during transportation, please prepare your own packaging bags and calcium oxide desiccant.
- Step2. According to the position shown in Figure 3-2 above, move the AIR75-2100B to the center of the base, and use an Allen wrench to tighten the M20 screws, washers, and M20 nuts connecting the AIR75-2100B, the base, and the end support, that is, the manipulator can be fixed to the bottom bracket.

Step3. Place the box on the bottom bracket according to the position shown in Figure 3-2 above. Use a wrench to tighten the screws, washers and nuts of the box and bottom bracket to fix the box and bottom bracket.

### 3.2.3. Safe disposal of packaging materials

- In order to facilitate repacking, please properly save the carton, the bottom bracket and all the screws and nuts and other parts used in connection. Please keep the above materials in a dry and clean indoor place to prevent the materials from moisture, pressure, heat or close to fire source.
- If you don't need to keep the above materials, please handle them properly according to the relevant disposal methods of industrial waste.
- The packaging bag and calcium chloride desiccant cannot be used again after unpacking, please handle it properly according to the relevant disposal methods of industrial waste.

### 3.2.4. Disposal of waste materials

Industrial robot system waste disposal must be carried out in accordance with the laws, regulations and standards of each country.

## 3.3. Preparation before installation

### 3.3.1. Installation Precautions

Before installing the manipulator, the items listed below must be strictly observed:

- Ensure that the installation staff must pass the relevant training of the company, and can only carry out installation work in compliance with international and local laws and regulations.
- After unpacking, make sure that the manipulator is not bumped and damaged.
- Make sure that the brackets and lifting eye screws used for transportation are installed on the manipulator as required.
- Ensure that the installation environment of the manipulator meets the requirements of *Chapter 1.2.1* of this manual.
- Make sure that the installation site of the manipulator can withstand the pressure or tension caused by the manipulator and its load.

### 3.3.2. Installation tools and required connectors

The following tools may be required to install the manipulator (more tools may be required, depending on the specific installation method):

- Anallen wrench
- Adjustable wrench
- Torque wrenches of different specifications, etc.

The connection parts that may be required for the installation of the manipulator are as follows (more connection parts may be required, depending on the specific installation):

- Several M20 or other size cylindrical head hexagon socket screws of appropriate length and strength grade 12.9.
- Several chemical bolts of appropriate length and strength grade no less than 4.8.
- Several  $\Phi 20$  or other specifications spring pads.
- Several cylindrical pins with a diameter of 10mm, etc. For details, please refer to "3.4.2 Fixing Method" in this manual.

## 3.4. Installation and assembly



### 3.4.1. Technical specifications

When installing the AIR75-2100B manipulator, full consideration should be given to the strength of the foundation installation surface. In addition, the inclination of the ground where the manipulator is installed must be less than 5°.

The dimensions of the AIR75-2100B base are shown in Figure 3-3.

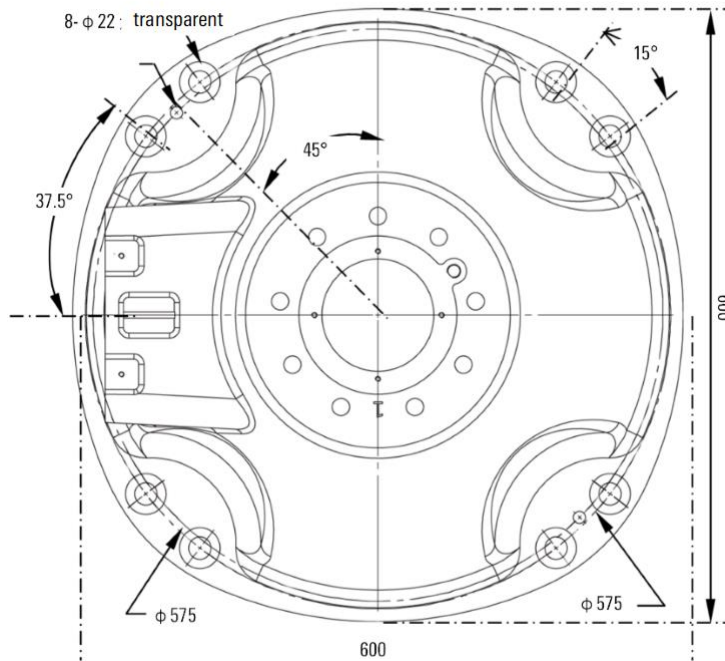



Figure 3-3 AIR75-2100B base interface size

### 3.4.2. Fixed way

The AIR75-2100B provides two fixing methods: "ground fixed" and "bracket fixed".

 Prompt	<ul style="list-style-type: none"> <li>■ The specific fixation method should be selected appropriately based on the environment in which the user is operating.</li> <li>■ Due to the fact that the strength of chemical bolts is influenced by the strength of concrete, it is necessary to refer to the design guidelines provided by manufacturers and consider safety precautions before using them during construction.</li> </ul>
-----------------------------------------------------------------------------------------------	-----------------------------------------------------------------------------------------------------------------------------------------------------------------------------------------------------------------------------------------------------------------------------------------------------------------------------------------------------------------------------------------------------------------------------------------

The required components and their specifications for the fixed manipulator are shown in Table 3-1.

Table 3-1 Parts required for fixing the AIR75-2100B

Component name	Remarks	Ground fixed	Bracket fixed
Fixing screw	4 M20x40 (Grade 12.9)	○	○
Chemical screw	8 M20 (strength grade not less than 4.8)	○	○
Robot fixed plate	Thickness 25mm, 1 piece	○	
Installation bracket	Thickness 25mm, 4 pieces		○

 Prompt	<ul style="list-style-type: none"> <li>■ There must be no insulating material between the robot fixed plate and mounting bracket and the manipulator.</li> <li>■ Those marked with "○" need this part.</li> <li>■ The bracket needs to be firmly installed on the ground, and its strength should be no less than the fixing strength between the robot fixing plate and the ground during ground fixation.</li> </ul>
---------------------------------------------------------------------------------------------	------------------------------------------------------------------------------------------------------------------------------------------------------------------------------------------------------------------------------------------------------------------------------------------------------------------------------------------------------------------------------------------------------------------------

Ground fixed

Fixed steps:

- Step1. Arrange M20 chemical bolts (strength grade not less than 4.8) on the concrete foundation according to the recommended dimensions shown in Figure 3-4. Please strictly follow the instructions for use of the selected chemical bolts for installation.
- Step2. Place the robot fixing plate close to the installation surface and fix it with 8 M20 chemical bolts (strength grade not less than 4.8) and M20 flat washers.
- Step3. In the carrying posture (refer to Chapter 7), transfer the manipulator to the top of the robot fixed plate, adjust the direction of the manipulator so that the  $\phi 22$  through hole of the base is aligned with the M20 threaded hole of the robot fixed plate.
- Step4. Check whether the base is tightly attached to the fixing plate without shaking. Use 8 M20x40 bolts (strength grade 12.9) to securely install the manipulator base to the fixing plate.

 Prompt	<p>The surface of the fixed plate should meet certain roughness and flatness requirements, and the flatness of the mounting surface should be within 0.3.</p>
-----------------------------------------------------------------------------------------------	---------------------------------------------------------------------------------------------------------------------------------------------------------------

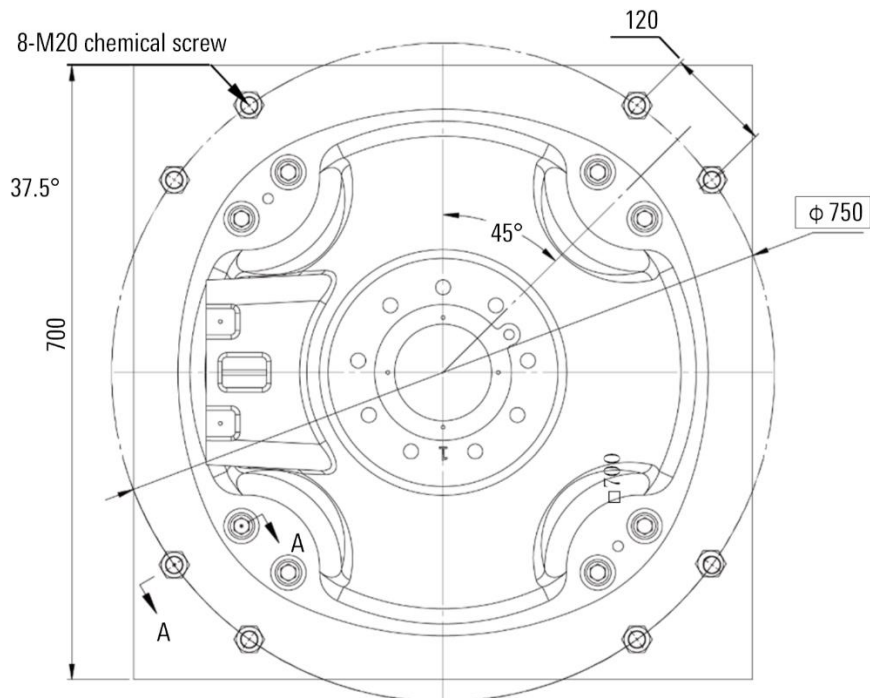

(a) Floor layout dimensions

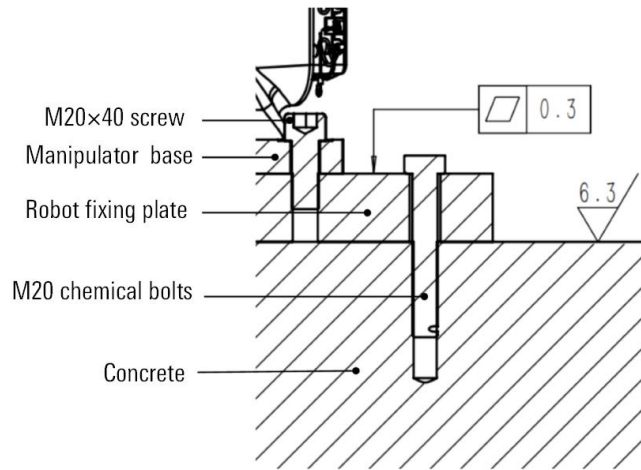

(b) Section view

Figure 3-4 Diagram of ground fixation of the manipulator

### Bracket fixed

 Warning	<ul style="list-style-type: none"> <li>■ The length of the M20 fixing screw for the manipulator should not be less than 40mm, as too short a length can cause accidents such as poor fixation.</li> <li>■ When installing the suspended ceiling of the manipulator, it is necessary to increase the length of the fixing screws of the manipulator to 45mm, while ensuring that the thickness of the installation plate is not less than 30mm.</li> </ul>
-----------------------------------------------------------------------------------------------	-----------------------------------------------------------------------------------------------------------------------------------------------------------------------------------------------------------------------------------------------------------------------------------------------------------------------------------------------------------------------------------------------------------------------------------------------------------

#### Fixed steps:

- Step1. Fix the four mounting brackets with 8 M20 chemical bolts (strength grade not less than 4.8), as shown in Figure 3-5.
- Step2. In the transportation posture, transfer the manipulator to the top of the mounting bracket, adjust the direction of the manipulator, and align the  $\phi 22$  through hole of the base with the M20 threaded hole of the mounting bracket.
- Step3. Check whether the base is tightly attached to the surface of the mounting bracket without shaking. Use 8 M20x40 bolts (strength grade 12.9) to secure the manipulator base to the bracket. The mounting surface of the bracket should meet certain flatness requirements.

 Prompt	<p>The mounting surface of the bracket should meet certain flatness requirements, and the flatness of the mounting surface should be within 0.5.</p>
-----------------------------------------------------------------------------------------------	------------------------------------------------------------------------------------------------------------------------------------------------------

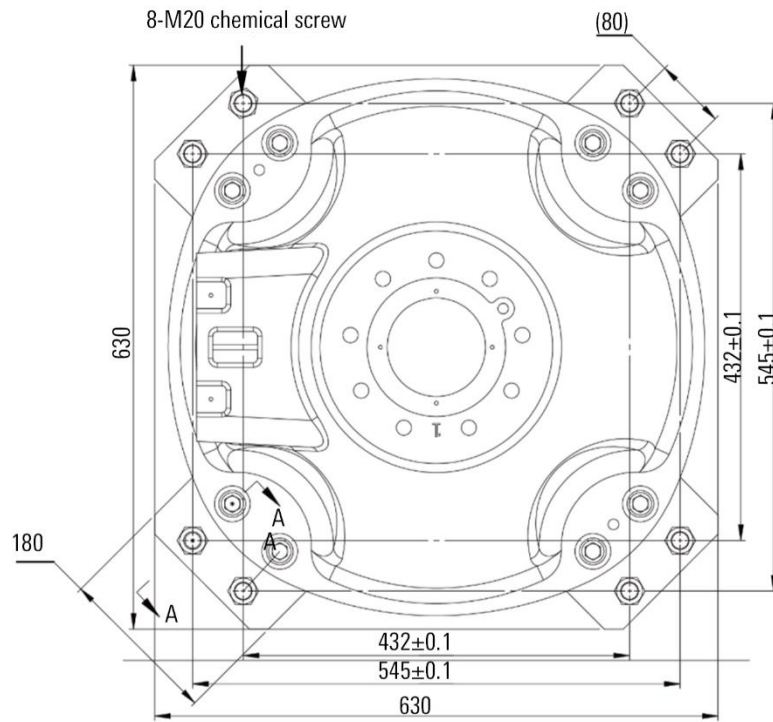

(a) Floor layout dimensions

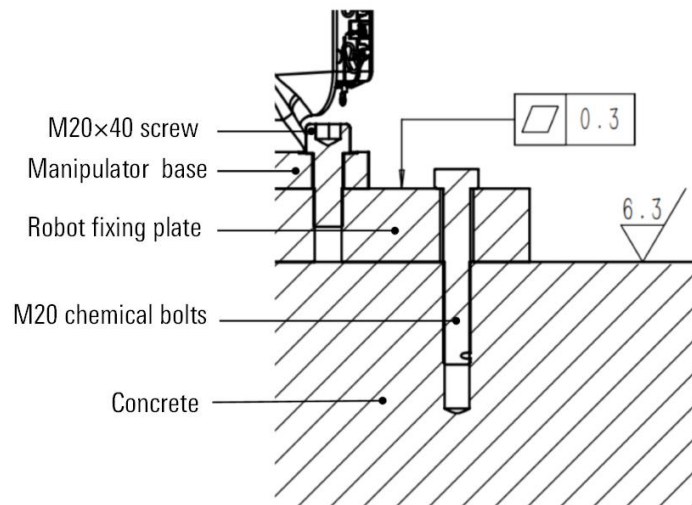

(b) Sectional view

Figure 3-5 Diagram of manipulator bracket fixation

## 4. Electrical interface

### 4.1. Manipulator electrical interface type

There are aviation plugs, heavy-duty connectors, and air pipe joints on the base of the AIR75-2100B. As shown in Figure 4-1, from left to right are Wien HDD-042 type, HF24B modular type, IO interface socket SA2015-P12B and  $\Phi 10$  Tracheal connector.

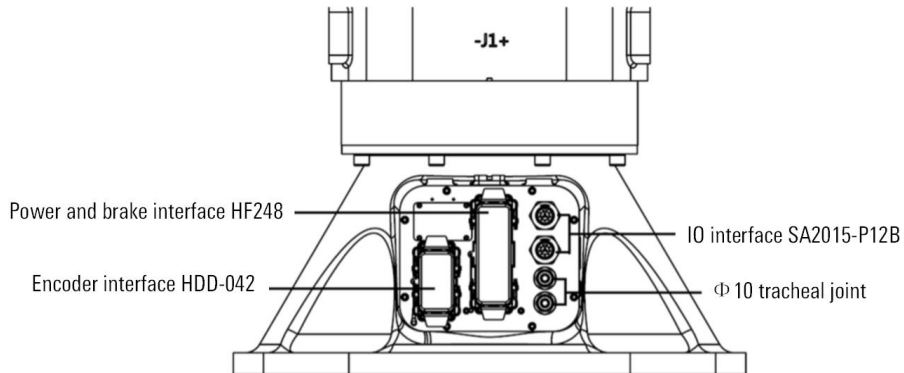

Figure 4-1 Heavy-duty connector on the AIR75-2100B

### 4.2. Heavy-load line interface on the manipulator side

The diagram of the heavy load and aviation insertion interface of the AIR75-2100B is shown in Figure 4-2.

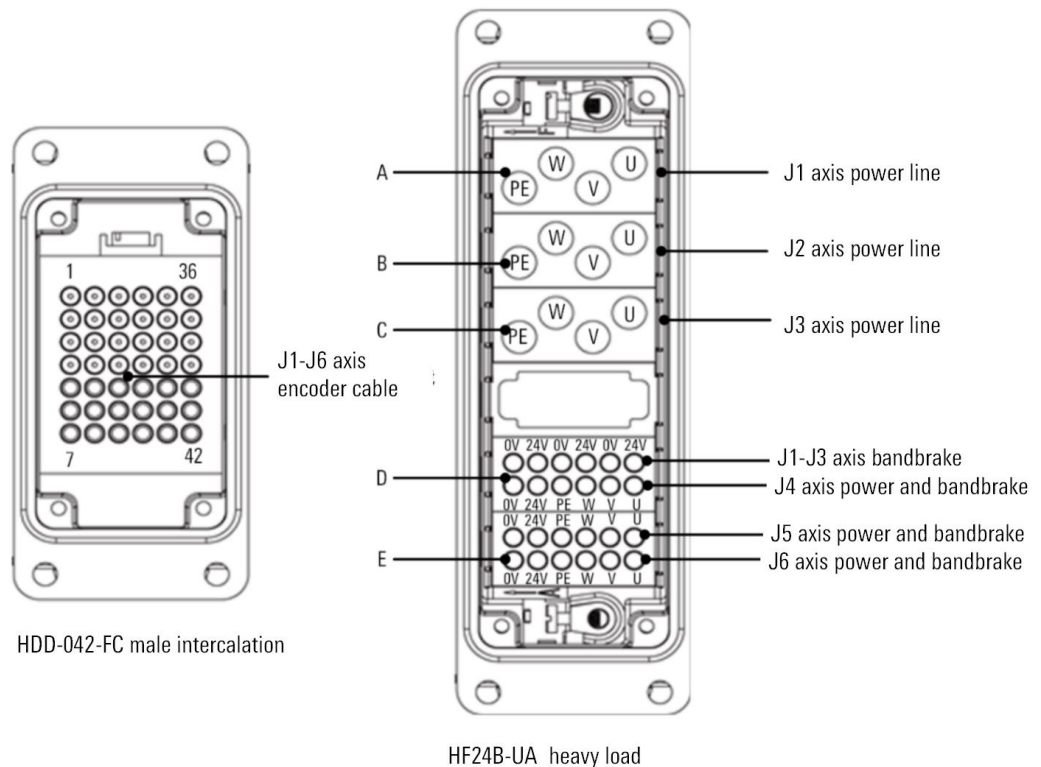

Figure 4-2 AIR75-2100B heavy load interface definition

## Encoder interface HDD-042 interface definition

Encoder interface HDD-042 interface definition, please refer to Table 4-1.

Table 4-1 Encoder interface HDD-042 interface definition

Pin	Definition	Pin	Definition	Pin	Definition	Pin	Definition	Pin	Definition	Pin	Definition
1	J1_PS-	8	J2_PS-	15	J3_PS-	22	J4_PS-	29	J5_PS-	36	J6_PS-
2	J1_PS+	9	J2_PS+	16	J3_PS+	23	J4_PS+	30	J5_PS+	37	J6_PS+
3	J1_0V	10	J2_0V	17	J3_0V	24	J4_0V	31	J5_0V	38	J6_0V
4	J1_5V	11	J2_5V	18	J3_5V	25	J4_5V	32	J5_5V	39	J6_5V

## Power and brake interface HF24B interface definition

Please refer to Table 4-2 for the interface definition of power and brake interface HF24B.

Table 4-2 Power and brake interface HF24B interface definition

Plug A-HMK-004-FC			
Pin	Definition	Pin	Definition
A1	U1	A2	V1
A3	W1	A4	PE
Plug B-HMK-004-FC			
Pin	Definition	Pin	Definition
B1	U2	B2	V2
B3	W2	B4	PE
Plug C-HMK-004-FC			
Pin	Definition	Pin	Definition
C1	U3	C2	V3
C3	W3	C4	PE
Plug D- HMD-012-FC			
Pin	Definition	Pin	Definition
D1	U4	D2	V4
D3	W4	D4	PE
D5	J4_24V	D6	J4_0V
D7	J1_24V	D8	J1_0V
D9	J2_24V	D10	J2_0V
D11	J3_24V	D12	J3_0V
Plug E- HMD-012-FC			
Pin	Definition	Pin	Definition

E1	U6	E2	V6
E3	W6	E4	PE
E5	J6_24V	E6	J6_0V
E7	U5	E8	V5
E9	W5	E10	PE
E11	J5_24V	E12	J5_0V

Encoder wire specification

Please refer to Figure 4-3 and Table 4-3 for the diagram and specification of the encoder cable. Please refer to Figure 4-4 and Table 4-4 for the dimensions of the heavy load connector of the encoder cable.

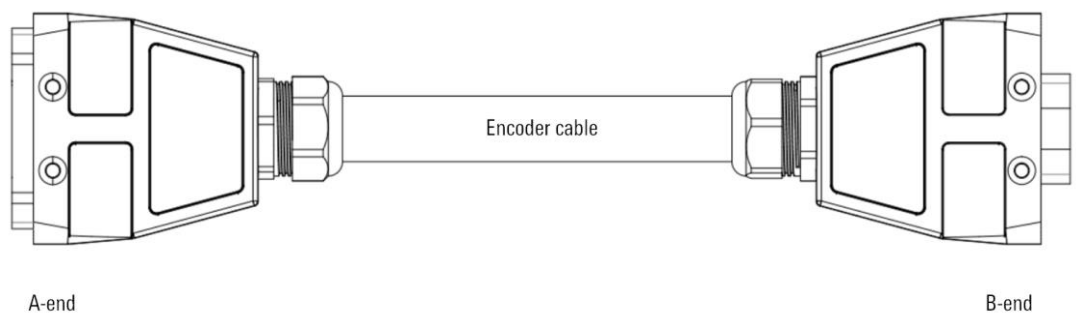

Figure 4-3 Diagram of ARC4-50 encoder wire

Table 4-3 ARC4-50 encoder wire specification table

Name	A-end connection form	B-end connection form	Wire diameter /mm	Minimum bending radius
ARC4-50 encoder cable	Buckle connection	Buckle connection	11	8D

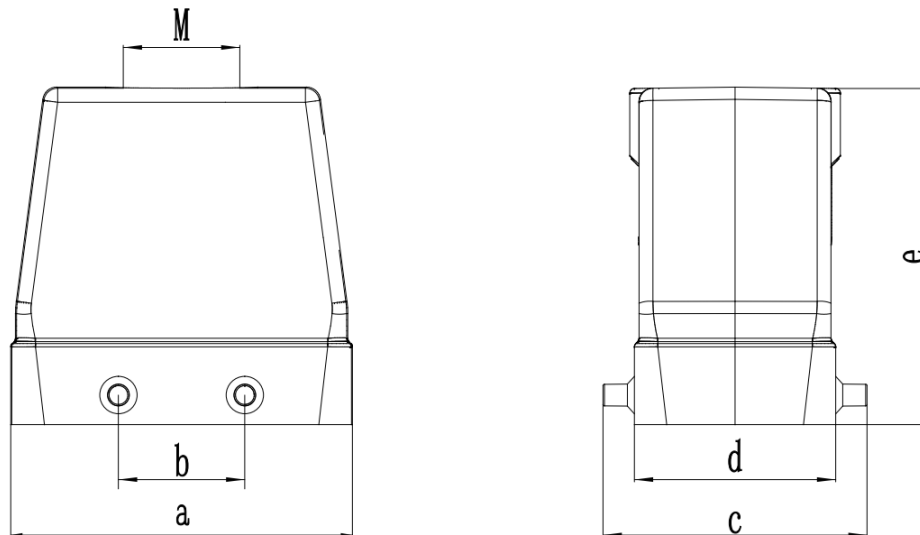

Figure 4-4 Encoder wire heavy load joint size

Table 4-4 Encoder wire load connector size table

Control cabinet	a	b	c	d	e	M
ARC4-50	73	27	56.4	43	72	M25

Power line specification

Please refer to Figure 4-5 and Table 4-5 for the diagram and specifications of the power line. Please refer to Figure 4-6 and Table 4-6 for the dimensions of the heavy-load power line connectors.

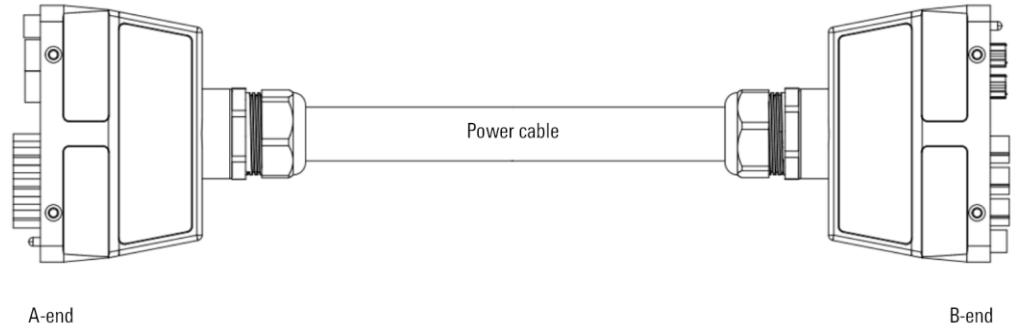

Figure 4-5 Diagram of ARC4-50 power line

Table 4-5 ARC4-50 power line specification table

Name	A-end connection form	B-end connection form	Wire diameter /mm	Minimum bending radius
ARC4-50 power line	Buckle connection	Buckle connection	23	8D

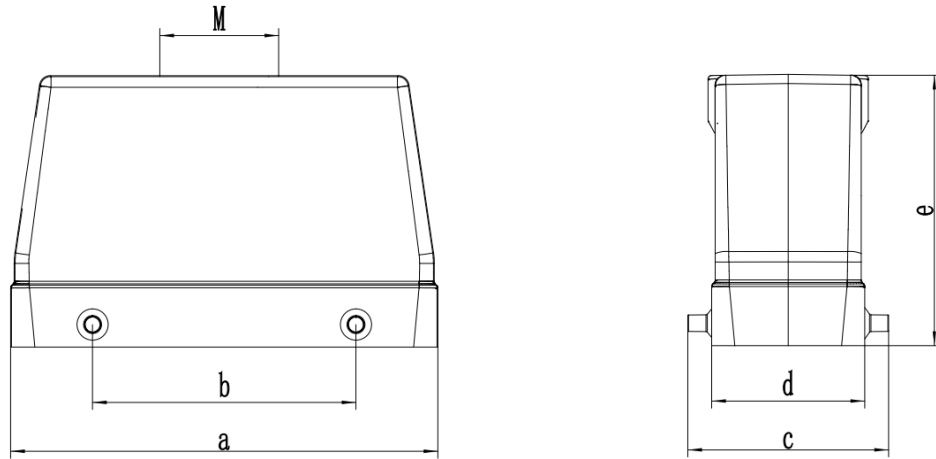

Figure 4-6 Size of power line heavy-load connector

Table 4-6 Power line heavy load connector size table

Control cabinet	a	b	c	d	e	M
ARC4-50	120	74	56.4	43	76	M32



## 5. Adaptation and connection of products with other devices

### 5.1. Connection between manipulator and control cabinet

As described in section 4.2 'Manipulator overload connector' of this manual, the main body of the manipulator is connected to the control cabinet through two cables. The ends of the overload cables are used to connect the manipulator and the control cabinet (see Figure 5-1 and Figure 5-2).

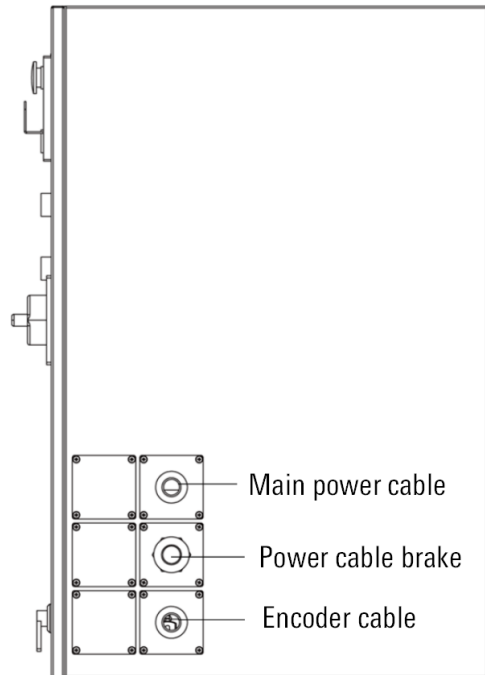

Figure 5-1 Definition of AIR75-2100B control cabinet cable connector

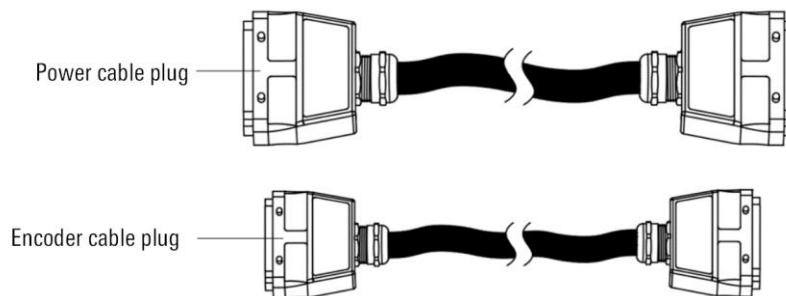

Figure 5-2 Overload line diagram

Connection steps:

Step1. Insert one end of the power cable and the encoder plug into the corresponding connection port of the heavy-duty cable of the manipulator (see Figure 5-3), and tighten the lock.

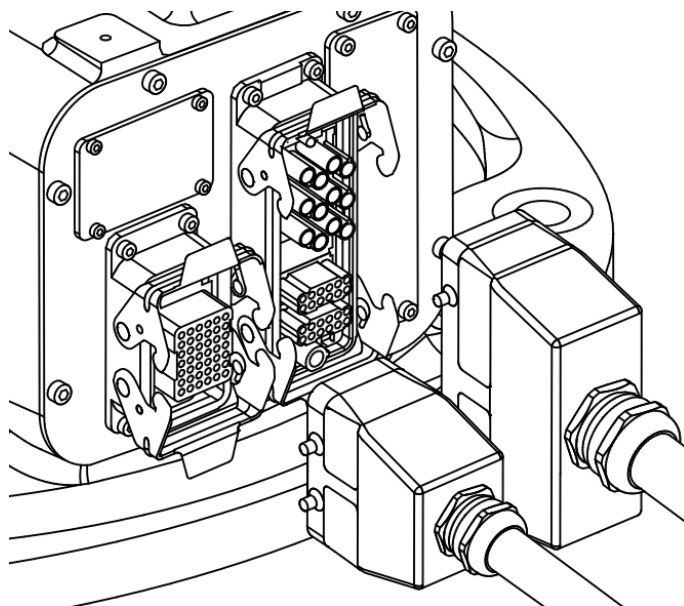

Figure 5-3 Manipulator heavy-load line connection interface

- Step2. Insert one end of the power cable and the encoder plug into the corresponding connection port of the heavy-load cable of the control cabinet (see Figure 5-4), and fasten the lock.

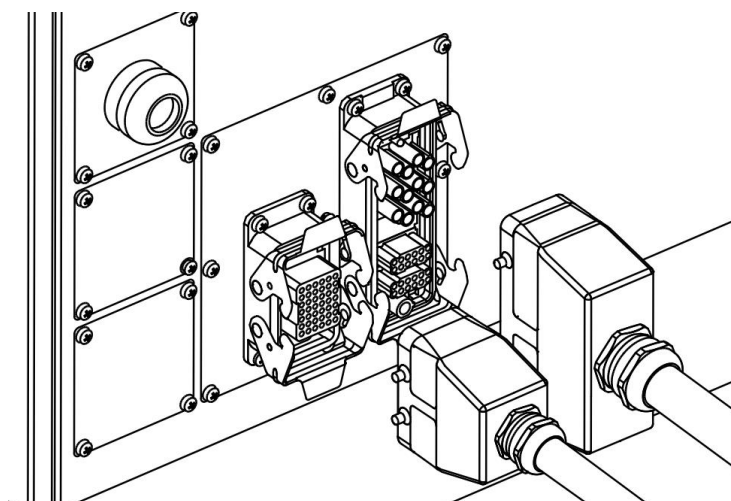

Figure 5-4 Control cabinet heavy load connector interface

## 5.2. Manipulator and power supply connection

Both ends of the power cord are used to connect the control cabinet and power supply respectively (see Figure 5-5).

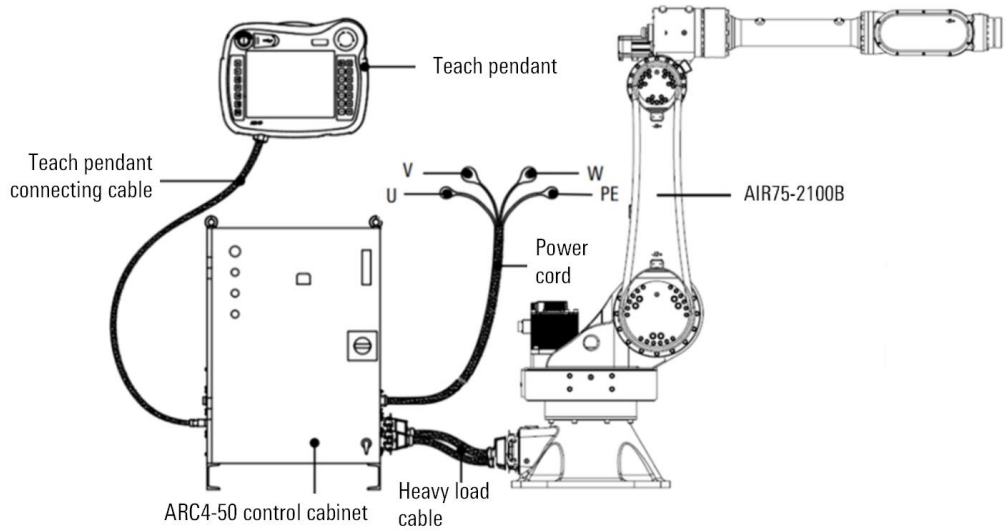

Figure 5-5 Industrial robot system wiring overview

Connection steps:

- Step1. Confirm that the power supply voltage and current on site meet the needs of the control cabinet (provide 380VAC voltage and meet a peak current load of at least 10A).
- Step2. After power is supplied, turn the handle of the circuit breaker (see Figure 5-6) and start the control cabinet. After starting, the "main power" indicator light (see Figure 5-7) on the control cabinet turns on and the teach pendant starts.

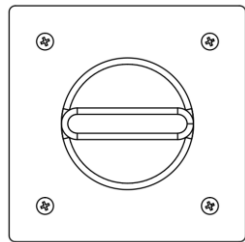

Figure 5-6 Control cabinet circuit breaker handle

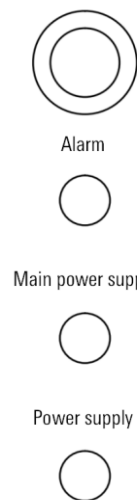

Figure 5-7 Control cabinet indicator light

Step3. Before powering off, please confirm that the program has stopped running. After powering off the motor, turn off the circuit breaker on the control cabinet.

### 5.3. Connection of manipulator and accessories

The connection between the external ancillary equipment of the manipulator and the manipulator is similar to the connection between the load and the manipulator. They can be connected to the manipulator directly or indirectly through flanges. Please refer to "0 Output Flange Dimensions" in this manual.

### 5.4. Examples of attachment types

The accessories of the manipulator mainly include mechanical grippers (as shown in Figure 5-8), hydraulic and pneumatic suction cups (as shown in Figure 5-9), welding torch welding machines (as shown in Figure 5-10), infrared identification equipment, visual identification equipment, cutting machines, and other special equipment.

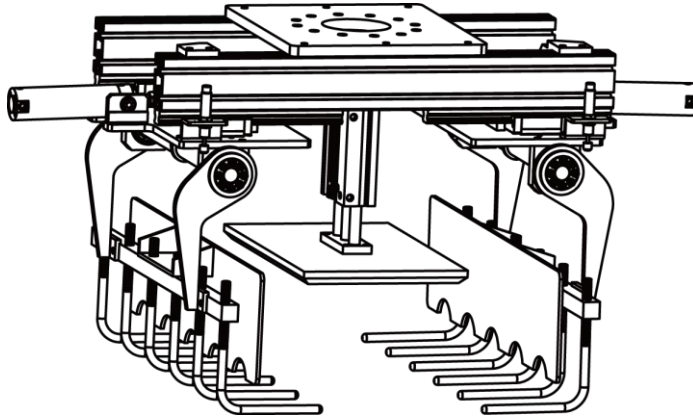

Figure 5-8 Industrial robot gripper

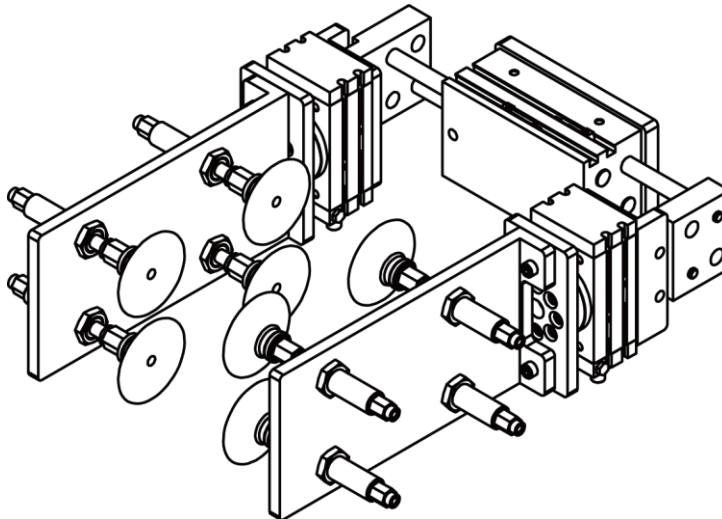

Figure 5-9 Suction cups for industrial robots

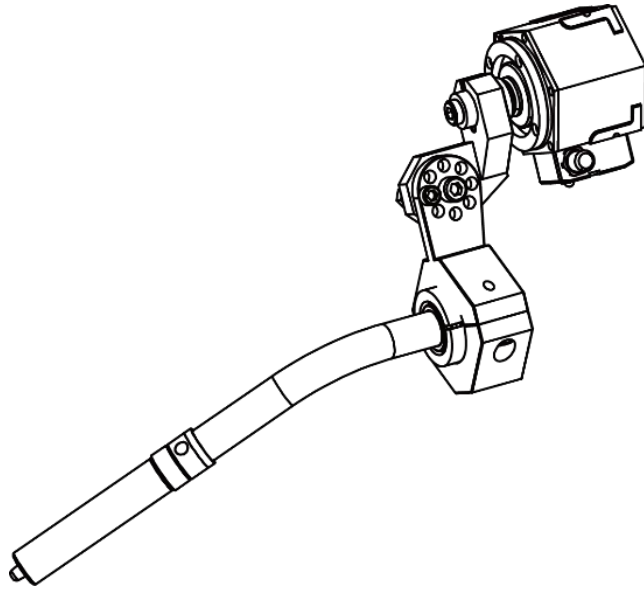

Figure 5-10 Arc welding gun for industrial robots



## 6. Job description

### 6.1. Safe operation

#### 6.1.1. Dimensions and working range of each axis

The movement range of each axis of the manipulator AIR75-2100B is shown in Table 6-1.

Table 6-1 Movement range of each axis of AIR75-2100B manipulator

Axis number	Range of motion (°)
J1	-185°~185°
J2	-75°~145°
J3	-120°~170°
J4	-350°~350°
J5	-120°~120°
J6	Unlimited

The operating range diagram of the manipulator is shown in Figure 6-1.

When installing peripheral equipment, care should be taken to avoid interfering with the main body and movement range of the robot. Unit: mm.

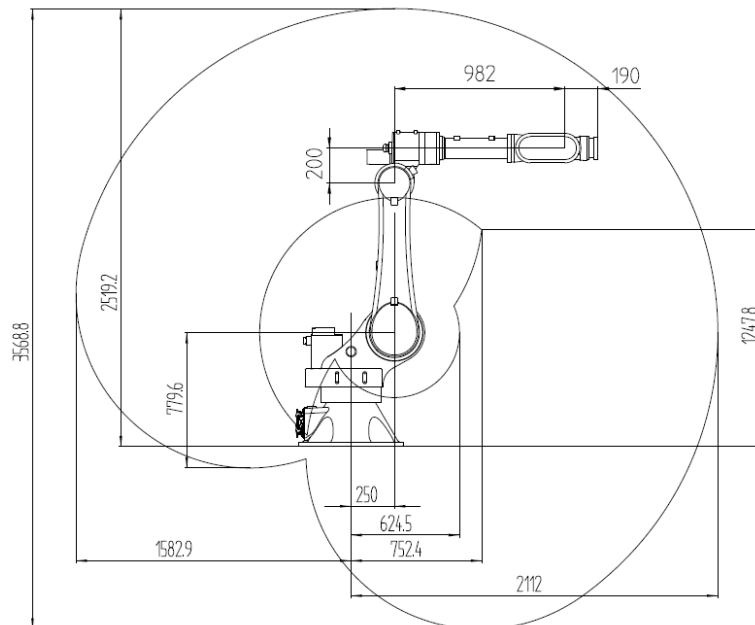

(a)

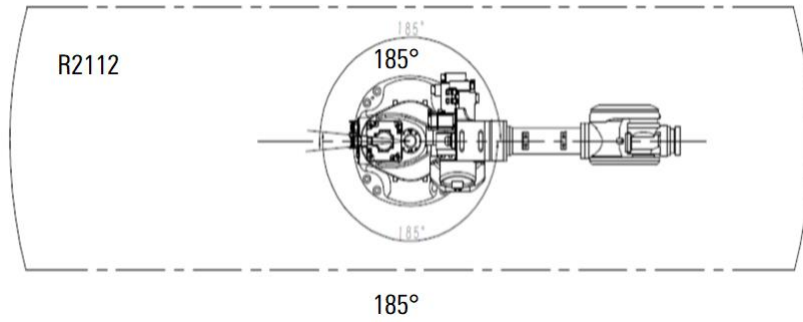

(b)

Figure 6-1 AIR75-2100B manipulator working range

### 6.1.2. Mechanical limit

Each axis is equipped with a zero point and a movable range. As long as the origin position is not lost due to servo system abnormalities or system errors, the robot is controlled to move within the movable range. In addition, to further ensure safety, mechanical brakes are provided on some axes to limit the range of movement.

The mechanical brake position is shown in Figure 6-2.

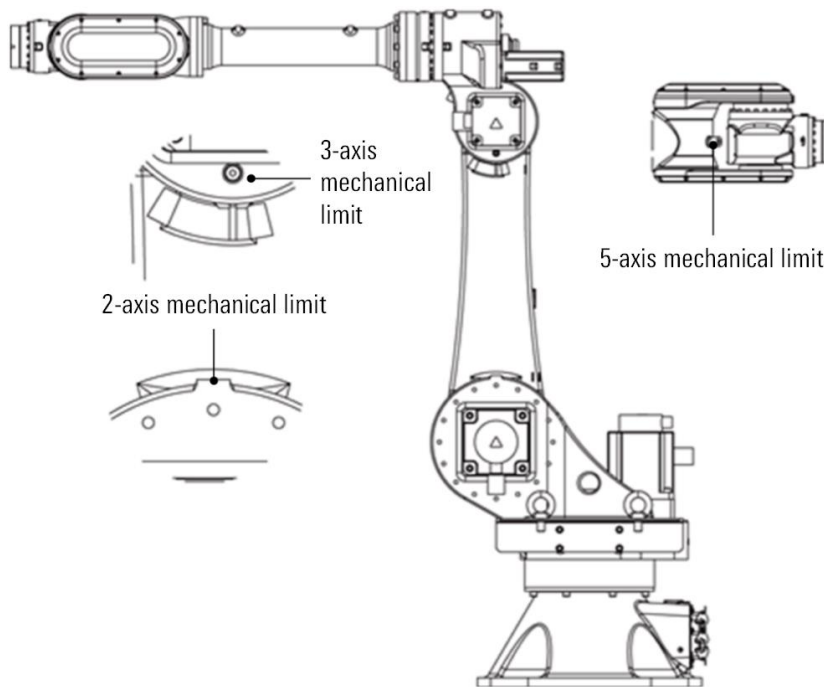



Figure 6-2 AIR75-2100B manipulator mechanical brake

 Caution	Do not modify the mechanical brake, otherwise the robot may not stop properly.
------------------------------------------------------------------------------------------------	--------------------------------------------------------------------------------

### 6.1.3. Stopping method

Please refer to Table 6-2 for the robot stopping method and corresponding instructions.



Table 6-2 Stop methods and corresponding instructions

Type	Illustrate	
STOP0	Case1	PLC_INT alarm stop0 indicate, the drive execution stops immediately without maintaining the trajectory, and then the PLC_INT delay control cuts off the power supply through the contactor, which is an uncontrollable stop.
	Case2	An uncontrollable fault occurs in the driver and triggers a free stop or brake stop, which is an uncontrollable stop.
	Case3	If the external power is suddenly cut off, the driver cannot stop immediately and triggers the brake to stop, which is an uncontrollable stop.
STOP1	Make the robot stop quickly and keep the current planned path. When the robot stops, control the driver servo_off and cut off the power supply through the contactor, which is a controlled stop.	
STOP2	The robot is stopped quickly and the current planned path needs to be maintained. When the robot stops, it does not servo_off and does not cut off the power supply. It is a controlled stop.	

## 6.2. Calibration

### 6.2.1. When calibration is required

When the manipulator encounters the following situations, it needs to be recalibrated:

- There have been repairs such as motor replacement or pulley removal.
- The encoder battery has been replaced.
- The motor encoder wire is loose or has been reinstalled.
- The manipulator has experienced a strong collision.
- The control cabinet or control system (such as industrial computer) has been replaced.

### 6.2.2. Calibration position of each axis

The calibration position of each axis of the manipulator is shown in Figure 6-3 below. Except for the J3 axis, which is 90° after calibration, the other axes are all 0°.

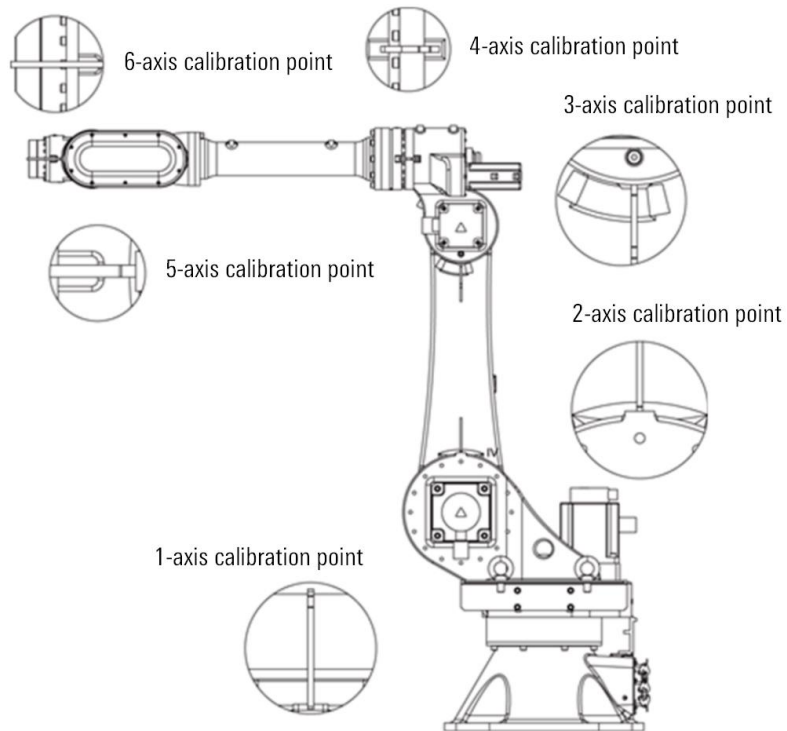



Figure 6-3 Diagram of zero points for each axis of AIR75-2100B

 Warning	<ul style="list-style-type: none"> <li>■ Robot calibration must always be performed under the same temperature conditions to avoid errors caused by thermal expansion and contraction.</li> <li>■ Calibration of AIR75-2100B industrial robot must be done in the order of J1 axis to J6 axis.</li> </ul>
-----------------------------------------------------------------------------------------------	-----------------------------------------------------------------------------------------------------------------------------------------------------------------------------------------------------------------------------------------------------------------------------------------------------------

### Calibration with high repeatability and positioning accuracy requirements

During the operation of the manipulator, as long as it requires high repeatability positioning accuracy, there is no requirement for path positioning accuracy. According to the zero point calibration positions of each axis shown in Figure 6-3, it can be aligned by visual observation, as shown in Figure 6-4.

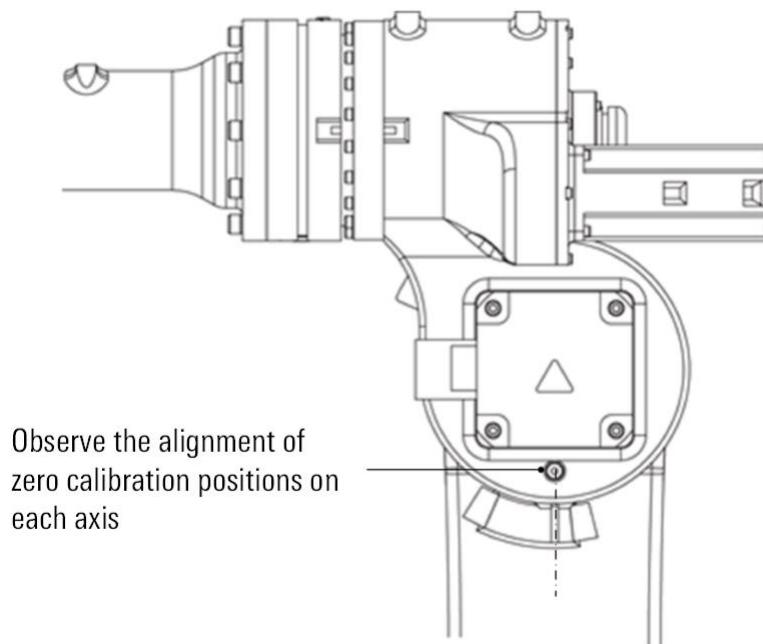



Figure 6-4 Visual observation of zero point calibration method

 Warning	During the calibration process of the manipulator, the speed should be reduced as much as possible. The operator is not allowed to enter the working range of the robot. After each robot stops moving, observe the alignment of the zero point scale on the axis position.
----------------------------------------------------------------------------------------------	-----------------------------------------------------------------------------------------------------------------------------------------------------------------------------------------------------------------------------------------------------------------------------

**Calibration when there are rough requirements for path positioning accuracy**

When there are rough requirements for path positioning accuracy, calibration block calibration is used, as shown in Figure 6-5.

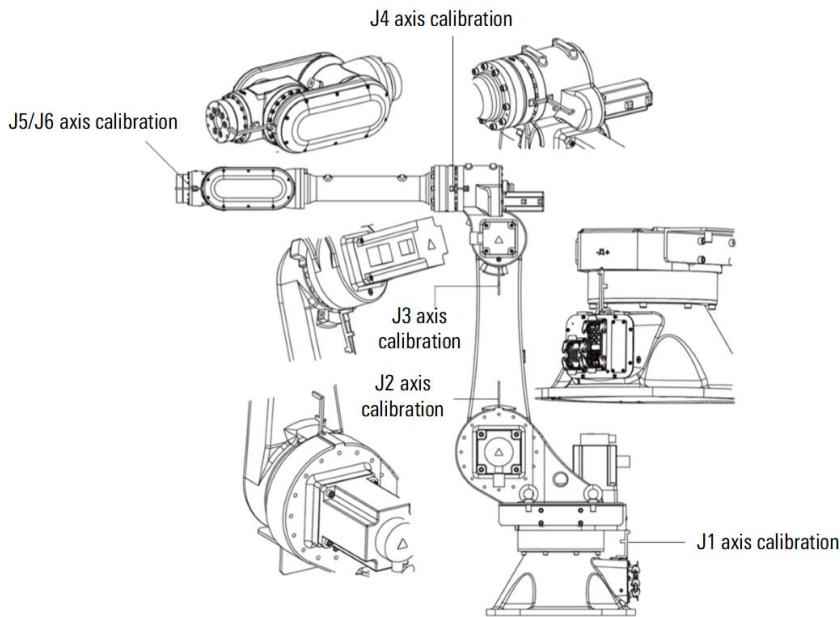



Figure 6-5 Zero point calibration block calibration method

 Warning	During the calibration process of the manipulator, the speed should be reduced as much as possible. The operator is not allowed to enter the working range of the robot. After each robot stops moving, observe the alignment of the zero point scale on the axis position.
 Caution	When using a calibration block to calibrate the manipulator, first visually observe the basic alignment of the calibration slots, then reduce the operating speed of the manipulator to the lowest manual gear. After fine-tuning the axis position, use the calibration block for calibration. After multiple fine-tuning, insert two calibration blocks at the same time. slot, as shown in Figure 6-5.

**Calibration when high path positioning accuracy is required**

When the operation of the manipulator requires high path positioning accuracy, it is necessary to accurately calibrate and compensate the angles and lengths of each axis. You need to contact our company to use special equipment for calibration.

**6.2.3. Movement direction of each axis**

For a 6-degree-of-freedom industrial robot manipulator, the movement direction is defined as shown in Figure 6-6. When viewed from right to left, the 2nd, 3rd, and 5th axes are positive clockwise and negative counterclockwise; Looking up and down, the 1st axis, 4th axis and 6th axis are positive counterclockwise and negative clockwise.

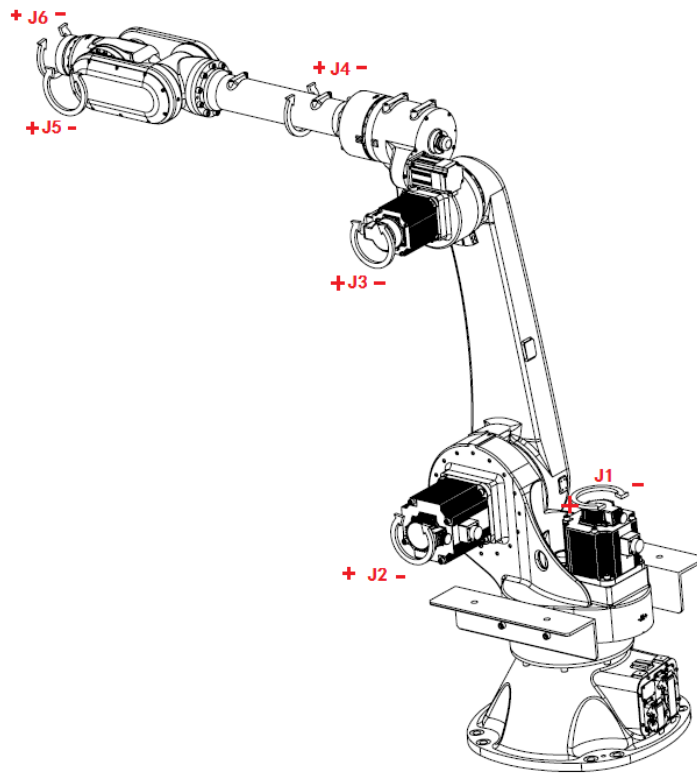

Figure 6-6 Movement direction of each axis of the manipulator

#### 6.2.4. Speed of each axis

The maximum angular speed of each axis of the manipulator is as required in Table 6-3.

Table 6-3 Maximum angular speed of each axis of the manipulator

Axis number	Maximum allowed angular velocity (°/s)
J1	177
J2	178
J3	173
J4	260
J5	255
J6	350

#### 6.3. Output flange size

The connection dimensions and diagram of the output flange of the AIR75-2100B are shown in Table 6-4 and Figure 6-7. The screw tightening torque is shown in Appendix B Screw Strength and Screw Tightening Torque Table (Nm).

Table 6-4 AIR75-2100B output mechanical interface specification

Parameter	Illustrate
Positioning circle diameter	40mm
Threaded hole indexing circle diameter	100mm

Parameter	Illustrate
Screw grade	12.9 grade
Screw diameter	M8
Number of screws	6
Positioning pin	4mm
Screw standard	GB/T 70.1-2000

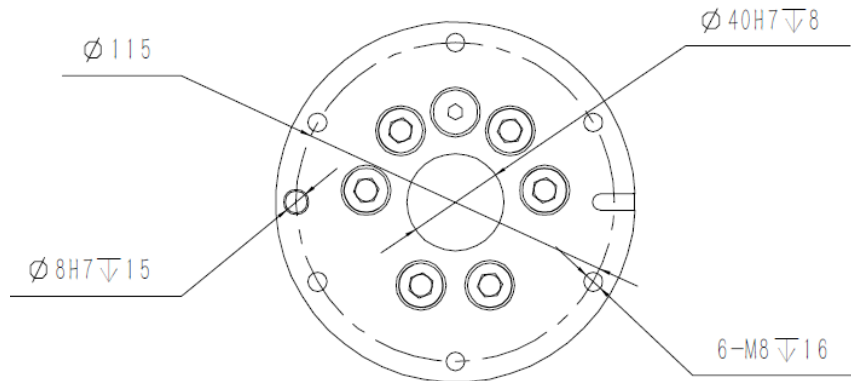



Figure 6-7 AIR75-2100B wrist flange size diagram

 Warning	<p>When installing the fixture, the screws and positioning pins used should fully consider the depth of the threaded hole and the pin hole. It is prohibited to install the length beyond the threaded hole depth (16mm) and the pin hole depth (15mm), otherwise the wrist of the manipulator will be damaged.</p>
------------------------------------------------------------------------------------------------	---------------------------------------------------------------------------------------------------------------------------------------------------------------------------------------------------------------------------------------------------------------------------------------------------------------------

## 6.4. Load and installation method

### Moment of inertia calculation method

The moment of inertia refers to how difficult it is for the load (end of fixture + workpiece) to rotate when the robot joint starts to rotate (the amount of inertia). The moment of inertia increases with load weight and eccentricity. Since this will also increase the load on the joints, make sure the moment of inertia is within the allowable value range.

Through the following formula, the moment  $M$  (N·m) and inertia moment  $I$  ( $\text{kgm}^2$ ) can be obtained when the load (end of fixture + workpiece) is small.

$$M(\text{N} \cdot \text{m}) = m(\text{kg}) \times L(\text{m}) \times g(\text{m}/\text{s}^2)$$

$$I(\text{kgm}^2) = m(\text{kg}) \times L^2(\text{m})$$

Among them,  $M$  is the load weight (kg),  $L$  is the load eccentricity (m), and  $g$  is the gravity acceleration ( $\text{m}/\text{s}^2$ ).

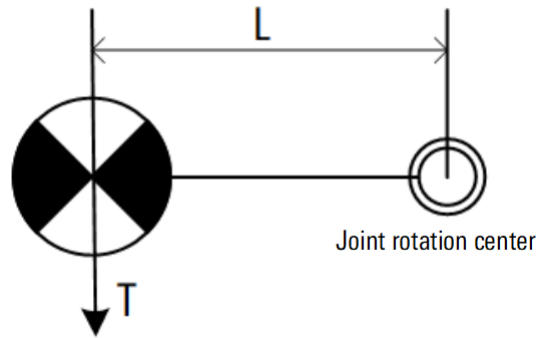

Figure 6-8 Load eccentricity diagram

### Installation of wrist load on the manipulator

Installation requirements:

- The load conditions should be within the range shown in Figure 6-9 and Table 6-5.
- The 4th axis allows a wrist torque less than 310Nm, the 5th axis allows a wrist torque less than 310Nm, and the 6th axis allows a wrist torque less than 180Nm.
- The 4-axis allows a load moment of inertia less than 30kgm<sup>2</sup>, the 5-axis allows a load moment of inertia less than 30kgm<sup>2</sup>, and the 6-axis allows a load moment of inertia less than 15kgm<sup>2</sup>.

Table 6-5 AIR75-2100B manipulator load torque and load moment of inertia data

Manipulator model	Axis	Load torque	Load moment of inertia
Wrist load 75kg		Nm	kgm <sup>2</sup>
AIR75-2100B	J4	310	30
	J5	310	30
	J6	180	15

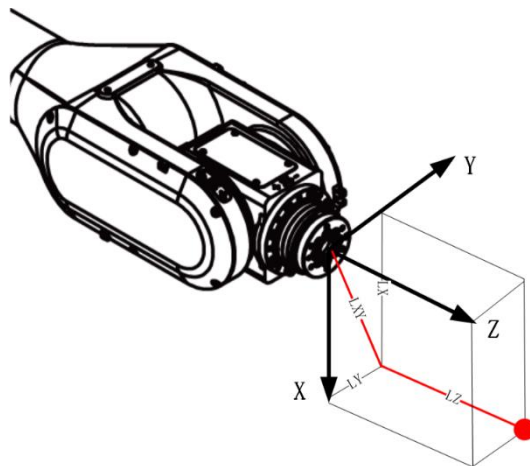

(a)

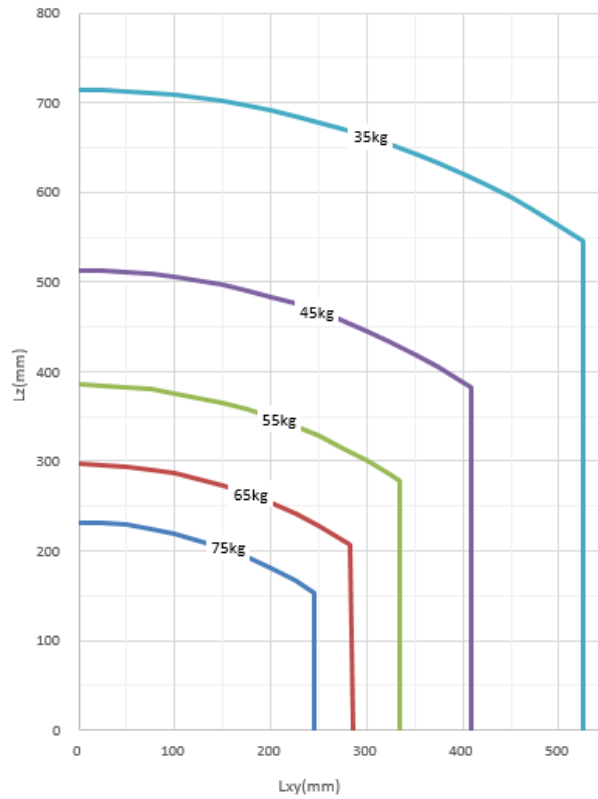

(b)

Figure 6-9 Diagram of AIR75-2100B wrist load centroid position

### Installation of 3-axis elbow equipment for the manipulator

Installation requirements:

- The AIR75-2100B manipulator can install external devices weighing no more than 20kg at the elbow.
- The center of gravity of the elbow load should not exceed the rectangular shape enclosed by the four M8 threaded holes in Figure 6-10, which is 200mm long, 150mm wide, and 150mm high.
- The height of the center of mass from the installation surface shall not exceed 60mm.

The specifications and dimensions of the installation holes for the J3 axis elbow of the AIR75-2100B are shown in Figure 6-10.

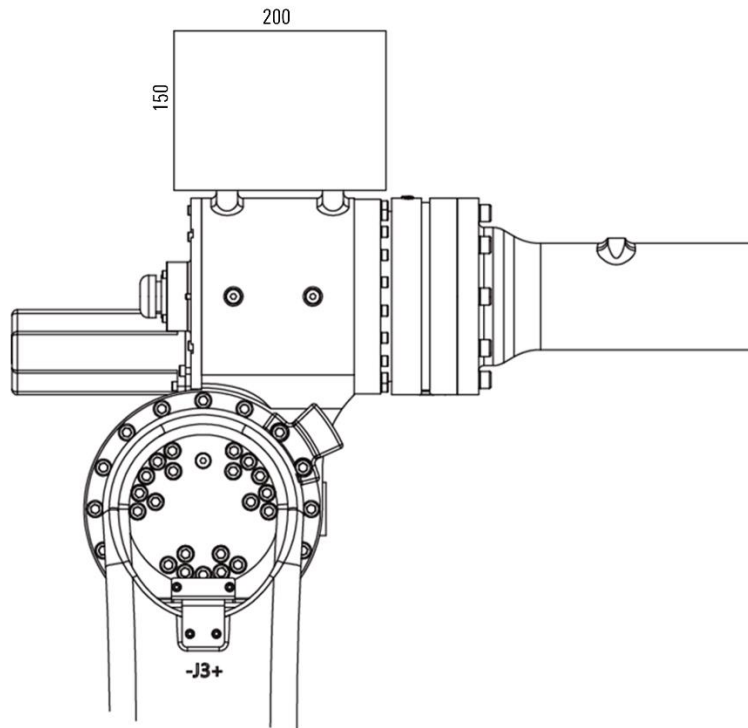

Figure 6-10 Diagram of AIR75-2100B elbow load interface size

The specifications and dimensions of the three-axis elbow load installation hole for the AIR75-2100B are shown in Figure 6-11.

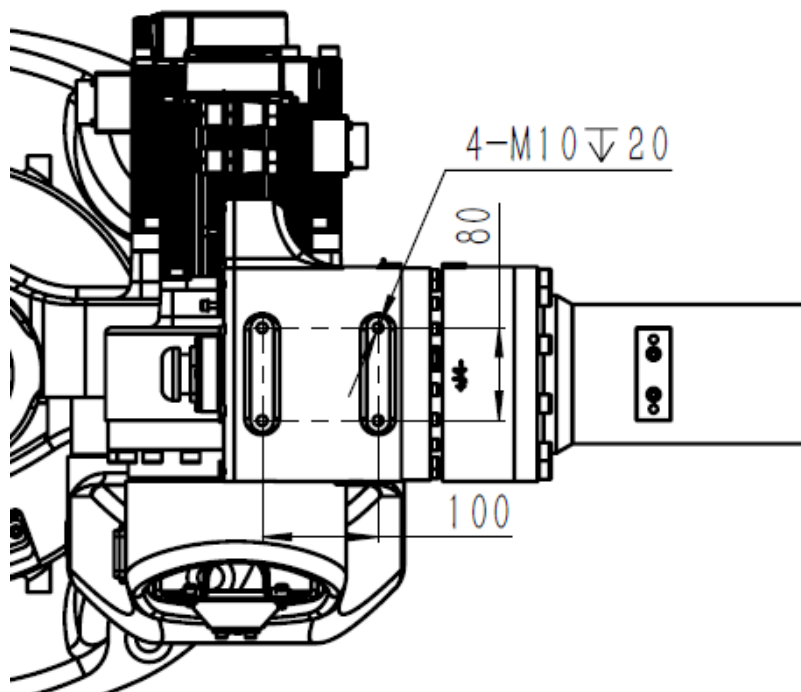



Figure 6-11 Diagram of AIR75-2100B elbow load interface size

 Warning	<ul style="list-style-type: none"> <li>When installing the equipment, full consideration must be given to the reliability of the installation. It is recommended to use 12.9 grade screws to install them according to the specified torque, and apply thread glue to the threads. Otherwise, they may loosen or even break during long-term operation, causing accidents.</li> </ul>
------------------------------------------------------------------------------------------------	---------------------------------------------------------------------------------------------------------------------------------------------------------------------------------------------------------------------------------------------------------------------------------------------------------------------------------------------------------------------------------------



- Never add machined holes or screw holes to the main body of the operating machine because it may adversely affect the safety and functionality of the operating machine.
- When installing equipment, the screws used should fully consider the depth of the threaded hole. It is prohibited to install the length beyond the depth of the threaded hole (10mm), otherwise the elbow of the operator will be damaged.
- The center of mass of the elbow load must not exceed the above values, otherwise the manipulator may alarm, fail to work normally, or reduce its working life.
- When installing equipment on the elbow of the manipulator, be careful to avoid interference with the manipulator and cables, which may cause the cables to break and lead to unexpected serious faults and consequences.

### Fixed position of manipulator forearm

Installation requirements:

- Forearm load + wrist load <75kg
- Elbow load <20kg

The specifications and dimensions of the mounting holes of the manipulator's forearm are shown in Figure 6-12.

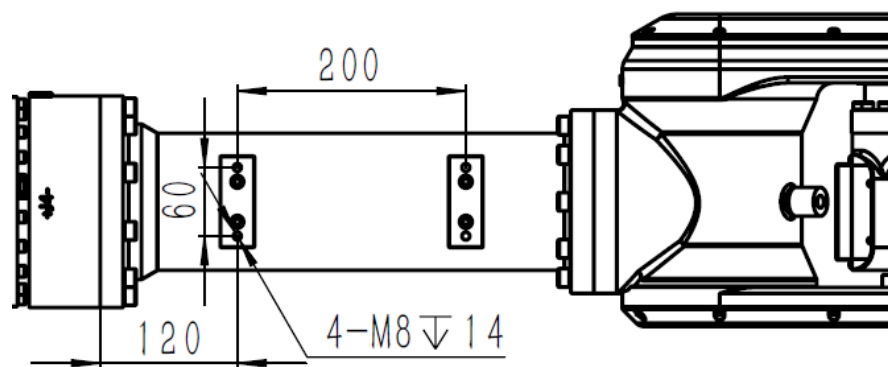

Figure 6-12 AIR75-2100B forearm interface dimension diagram



Warning

- When installing the equipment, full consideration must be given to the reliability of the installation. It is recommended to use 12.9 grade screws to install them according to the specified torque, and apply thread glue to the threads. Otherwise, they may loosen or even break during long-term operation, causing accidents.
- When installing equipment, the screws used should fully consider the depth of the threaded holes. It is prohibited to install the screws beyond the depth of the threaded holes, otherwise the internal components or cables of the manipulator will be damaged.



## 7. Transportation and handling



Caution

When transporting the manipulator, a matching transport bracket (optional accessory) must be installed. Incorrect transport methods may cause damage to the manipulator. The posture of the manipulator during transport shall be subject to the description in "7.1 Transport posture" of this manual. Things that should be paid attention to when transporting the manipulator are shown in Figure 7-1.

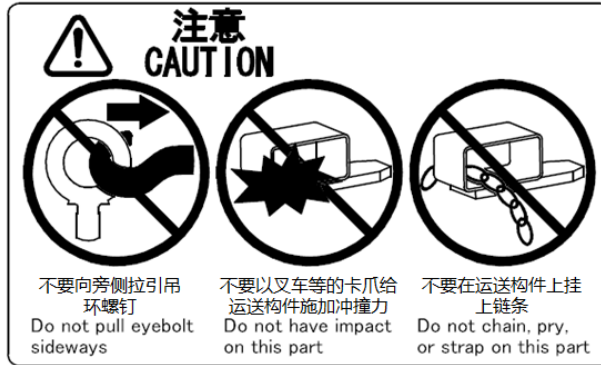

Figure 7-1 Precautions when transporting the manipulator

### 7.1. Transport attitude

The postures of one to six axes when handling the AIR75-2100B are as shown in Table 7-1.

Table 7-1 Angle value of each axis during robot transportation

A1	A2	A3	A4	A5	A6
0	-35°	170°	0	45°	0

Please see Figure 7-2 for the rendering of the one to six-axis attitude of the AIR75-2100B when being transported.

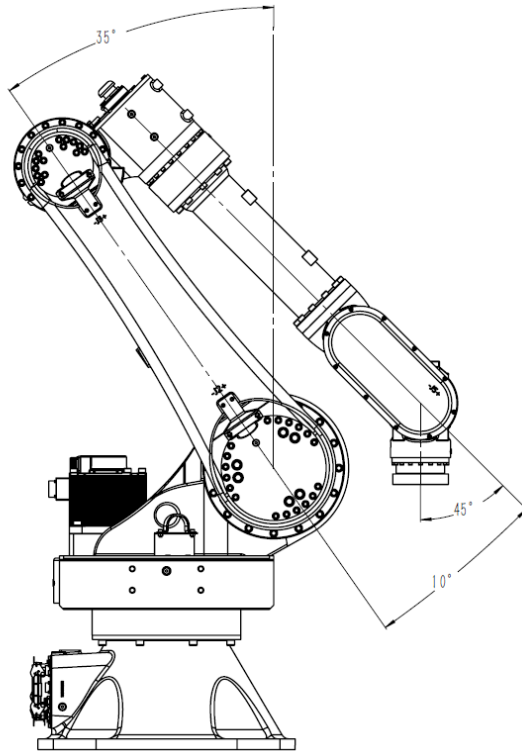



Figure 7-2 AIR75-2100B manipulator handling posture diagram

 Warning	<ul style="list-style-type: none"> <li>■ The manipulator must strictly follow the posture in Table 7-1 when transporting it, otherwise it may tip over due to unstable center of gravity.</li> <li>■ When the manipulator is transported over long distances, a wooden support must be added between the forearm and the two-axis reducer casting to reduce the impact load during transportation. The wood and the support points are separated by soft mats to prevent the wood from scratching the surface of the manipulator.</li> </ul>
------------------------------------------------------------------------------------------------	----------------------------------------------------------------------------------------------------------------------------------------------------------------------------------------------------------------------------------------------------------------------------------------------------------------------------------------------------------------------------------------------------------------------------------------------------------------------------------------------------------------------------------------------

## 7.2. Transport dimensions

The dimensions of the three views of the manipulator during transportation are shown in Figure 7-3.

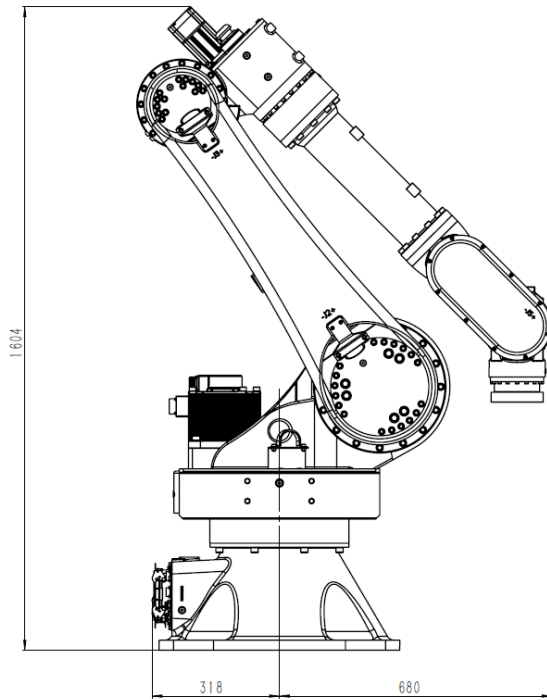

Figure 7-3 Dimensions of the AIR75-2100B when transporting

	The actual size may be slightly larger than the size in Figure 7-3, please note.
Caution	

### 7.3. Handling method

#### Forklift transportation

The diagram when using a forklift to transport is as shown in Figure 7-4. The forklift should be able to meet the weight requirement of the manipulator (530kg), and the total weight of the manipulator and the handling device is about 550kg.

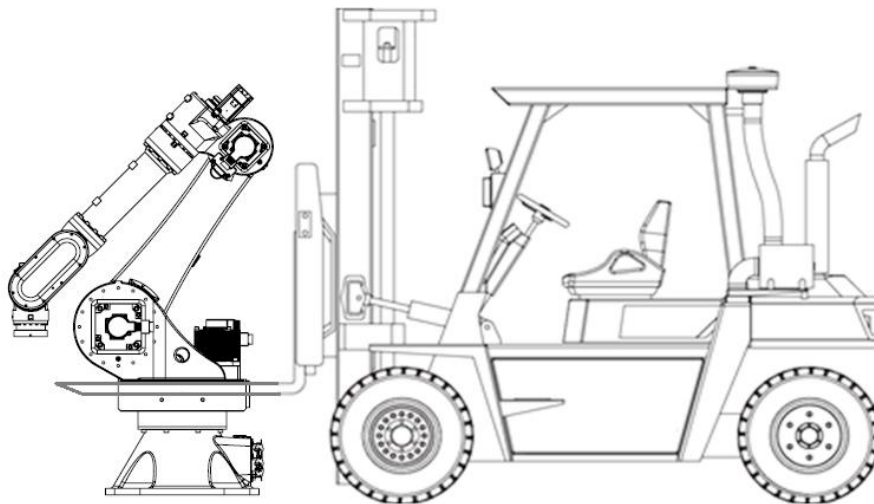



Figure 7-4 AIR75-2100B forklift handling diagram

 Caution	When transporting the manipulator, a matching transport bracket (optional accessory) must be installed. Incorrect transport methods may cause damage to the manipulator. The posture of the manipulator during transport shall be subject to the description in "7.1 Transport posture" of this manual. Things that should be paid attention to when transporting the manipulator are shown in Figure 7-1.
----------------------------------------------------------------------------------------------	------------------------------------------------------------------------------------------------------------------------------------------------------------------------------------------------------------------------------------------------------------------------------------------------------------------------------------------------------------------------------------------------------------

Ring handling

The diagram when the manipulator is transported using a lifting ring is shown in Figure 7-5 below. The lifting device should be able to meet the weight requirement of the manipulator (530kg). The total weight of the manipulator and transporting device is about 550k.

A single sling can carry a weight of more than 150kg, and a crane can carry a weight of more than 600kg.

 Caution	<ul style="list-style-type: none"> <li>■ When the manipulator is transported using a lifting ring, insert a soft object between the contact area between the lifting rope and the manipulator to prevent the lifting rope from scratching the manipulator.</li> <li>■ The manipulator may tip over when transported using lifting rings. Please be particularly careful to keep the manipulator stable during transportation.</li> <li>■ Do not pull the lifting ring sideways to avoid damage to the manipulator and unexpected malfunctions.</li> </ul>
----------------------------------------------------------------------------------------------	-----------------------------------------------------------------------------------------------------------------------------------------------------------------------------------------------------------------------------------------------------------------------------------------------------------------------------------------------------------------------------------------------------------------------------------------------------------------------------------------------------------------------------------------------------------

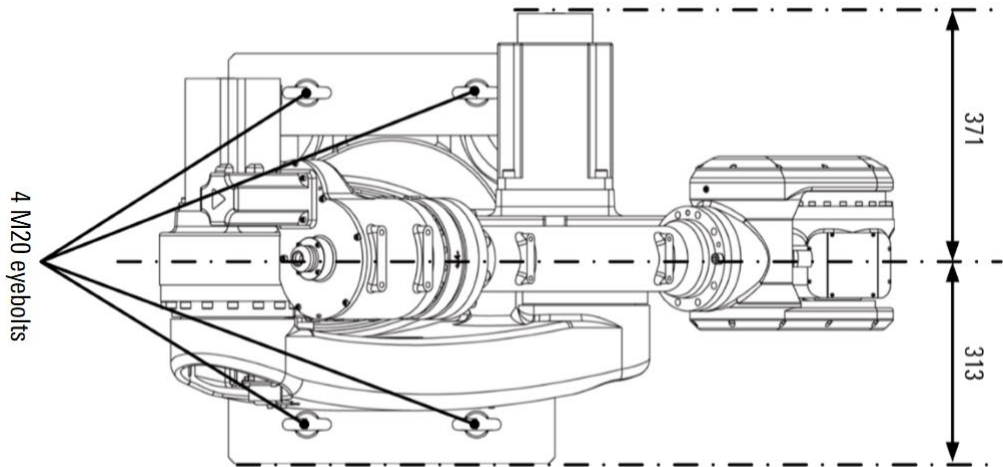

Figure 7-5 AIR75-2100B lifting ring handling diagram

## 8. General principles of maintenance

---

This manual provides instructions for preventive maintenance of the AIR75-2100B manipulator. For a complete industrial robot system maintenance, it should also include:

- For the maintenance of the control cabinet, please refer to the company's "ARC4-XX Control Cabinet Manual".
- For end effector maintenance, please refer to the relevant manuals (i.e., the relevant manuals for the end effectors provided by the user).



- Never perform any maintenance work before reading the general safety instructions and safety precautions, and maintenance work can only be completed by appropriately trained technicians.
- The primary goal of preventive maintenance is to ensure maximum utilization of the manipulator system. Every scheduled and properly performed periodic maintenance should help achieve this goal. If scheduled maintenance does not achieve the goal of reducing unit downtime, it is unnecessary and wasteful maintenance.
- Robotic systems are designed to work under quite demanding conditions and require minimal maintenance. Nonetheless, daily inspections and periodic maintenance must be carried out at given intervals.
- The time intervals in the maintenance table are recommended values. The actual time intervals required to maintain the manipulator may vary due to factors such as the actual working environment of the manipulator.
- When performing routine repairs or maintenance, numerous precautions must be kept in mind to avoid introducing additional errors or dangers into the system.
- Do not perform more scheduled maintenance than required on equipment that is operating well.
- All surfaces should be wiped clean before starting maintenance procedures.
- In order to avoid unnecessary contamination caused by dust and other debris, the outside of the control cabinet door and manipulator cover should be cleaned before opening them.

## 9. Preventive maintenance

---

### 9.1. Safety protection measures

#### Precautions during maintenance



Warning

- When the power is turned on, there is a danger of electric shock in part of the maintenance operations. The maintenance operations should be performed with the manipulator and system power off as much as possible; professional maintenance personnel should be designated as needed to perform maintenance operations; other personnel should be avoided during maintenance operations. Turn on the power; even in the case where the power must be turned on before the work can be performed, press the emergency stop button before proceeding.
- When you need to replace parts, please consult our company.
- The customer's independent replacement of parts may cause unexpected accidents, damage the manipulator, and cause injury to the operators.
- If you need to replace parts, be sure to use the parts designated by our company. If parts other than the specified parts are used, it may cause damage to the manipulator.
- When disassembling the motor and brake, take measures such as lifting by a crane before dismantling, so as to prevent the manipulator arm from falling
- During maintenance operations, when the manipulator needs to be moved due to unavoidable circumstances, the following items should be noted:
  - Make sure that the escape route is unblocked, and you should perform operations after you have grasped the operation of the entire system to avoid blocking the exit route by the manipulator and peripheral equipment
  - Always pay attention to whether there are dangers around and be prepared so that you can press the emergency stop button at any time when needed
- When moving parts with a certain weight such as motors and reducers, auxiliary equipment such as cranes should be used to avoid excessive work burdens on operators. At the same time, it is necessary to avoid wrong operation, otherwise it may cause injury or death of the operator.
- Be careful not to fall down because of the lubricating oil spilled on the ground. Wipe off the lubricating oil on the ground as soon as possible to eliminate possible dangers.
- During the operation, do not put any part of the body on any part of the manipulator, and it is forbidden to climb on the manipulator to avoid unnecessary personal injury or adverse effects on the manipulator.
- The following parts will generate heat, so be careful. When it is necessary to touch the device under heat, you should prepare protective equipment such as heat-resistant gloves:
  - Servo motor
  - Reducer
  - Components adjacent to the motor/reducer
  - Inside the control cabinet
- The parts (such as screws, etc.) that are removed when replacing parts should be correctly installed back to their original positions. If parts are found to be insufficient or there are remaining parts, they should be reconfirmed and installed correctly.
- When repairing the pneumatic system and hydraulic system, be sure to release the internal pressure to 0 before proceeding.
- When replacing parts, avoid dust and other foreign objects from entering the inside of the manipulator.
- Operators who perform maintenance and repair operations must be trained by our company and



pass relevant assessments.

- Appropriate lighting equipment should be equipped for maintenance work, but care should be taken not to make the lighting equipment the source of new hazards.
- Please refer to this manual for regular maintenance. Failure to perform regular maintenance will affect the service life of the manipulator and may result in accidents.

## Safety of maintenance engineers

In order to ensure the safety of maintenance engineers, the following items should be fully paid attention to:

- During the operation of the manipulator, do not enter the operating range of the manipulator.
- Carry out maintenance work with the power supply of the control device disconnected as much as possible. The main circuit breaker should be locked with a lock, etc. as needed to prevent other people from turning on the power.
- When it is necessary to enter the working range of the manipulator during power-on, you should press the emergency stop button of the control cabinet or the teach pendant before entering. In addition, the operator should put up a "maintenance operation" sign to remind other personnel not to operate the manipulator at will.
- Before performing maintenance work, confirm that the manipulator or peripheral equipment is in a safe state.
- Do not perform automatic operation when there are people in the operating range of the manipulator.
- When working near walls, appliances, etc., or when several operators are close, be careful not to block the escape passages of other operators.
- When there are knives on the manipulator, and when there are moving devices such as conveyor belts in addition to the manipulator, pay full attention to the actions of these devices.
- A person who is familiar with the manipulator system and can detect the danger should be arranged beside the operation panel and operation box during operation, so that they can press the emergency stop button at any time.
- When replacing parts or reassembling, pay attention to avoid foreign matter adhesion or mixing.
- When inspecting and repairing the inside of the control device, if you want to touch the unit, printed circuit board, etc., in order to prevent electric shock, be sure to disconnect the power supply of the main circuit breaker of the control device before proceeding.
- The replacement parts must use the parts designated by our company.
- When restarting the manipulator system after the maintenance work is completed, fully confirm in advance that no one is within the operating range of the manipulator, and that the manipulator and peripheral equipment are in normal state.

## 9.2. Daily maintenance

When operating the manipulator every day, check the items shown in Table 9-1.

Table 9-1 Daily maintenance items of the manipulator

No.	Check item	Check essentials
1	Vibration, sound, motor heating	Whether there is abnormal vibration or noise on each axis, and whether the motor temperature is abnormally high.
2	Whether the positioning accuracy changes	Check whether it deviates from the last start position and whether there is a deviation in the stop position
3	Operation confirmation of peripheral equipment	Confirm that the actions of the manipulator and peripheral equipment are consistent with the instructions

## 9.3. First maintenance

The operation machine shall run for the first time 320 hours or 1 month (whichever is shorter), and the following items shall be inspected and maintained. As shown in Table 9-2:

Table 9-2 Manipulator First Maintenance Project.

No.	Inspection item	Main points of inspection
1	Whether the cable and cable sheath of the manipulator are damaged differently and whether the motor connector is loose	Observe the cable activity part of the manipulator, check whether the cable is damaged, whether the cable is bent or distorted locally, check whether the cable sheath is damaged or not, and check whether the motor connector is loose (Note 1)
2	Tighten the main external bolts	Use a torque wrench to tighten the end effector mounting bolts and the main external bolts (see note 2 for the method)
3	Clean all parts of the manipulator	Clean and maintain the parts of the manipulator, and check whether the parts are damaged (Note 3).
4	Whether the end effector cable is damaged	Check whether the cable is damaged and whether the cable sheath is damaged.
5	Whether the timing belt is worn	Check the timing belt for wear, elongation, and breakage (Note 4)
6	Check whether the limit rubber blocks at the J2, J3 and J5 axes are damaged.	Check whether the limit rubber block is loose, damaged by collision, aging, etc.

Note 1:

#### Check and Repair Points

- Cables and cable sheaths inside the manipulator base (the electrical installation plate needs to be removed).
- The internal cables and cable sheaths between the manipulator boom and the J1 axis body.
- Manipulator connection cables, ground terminals, and user cable connectors.

#### Confirmation

- Check the line sheath for cracks and wear. If the sheath is damaged, replace it.
- Check whether the grease on the surface of the cables inside the J1 axis body and the cables inside the boom has disappeared. If the grease is about to disappear, replenish it.
- Check whether the wiring is worn, and if the internal wires are visible, replace them.
- Circular connector: Turn it by hand to see if it is loose.
- Square heavy load: Confirm whether the control rod has fallen off.
- Ground terminal: Check whether it is loose.

Note 2:

#### Fastening part

- Tighten the end effector mounting bolts, manipulator fixing bolts, etc.
- The external connection screws of the manipulator, especially the connection screws of each axis and the reducer.
- For tightening torque, please refer to the recommended values in the appendix of this manual.

Note 3:

#### About cleaning

- Regarding the parts that need to be cleaned and the accumulation of dust and splash on the surface, they should be cleaned regularly.

- Special attention needs to be paid to cleaning between the rotating parts of the J5 axis of the wrist, and debris should be removed in a timely manner.
- Confirm if there is oil leaking from the reducer or gear box.
- After wiping off the oil, if the oil is still visible after 1 day, there may be an oil leak.

Note 4:

About timing belt maintenance

- After removing the manipulator cover, observe whether the timing belt is worn or damaged. To remove the cover, please refer to "10.5 Replacing the Timing Belt" in this manual.
- Observe whether there is white hair inside the teeth of the timing belt, whether the belt side is worn, whether the belt teeth are crushed, whether the belt body is broken, whether the belt body is stretched (decreased preload), etc.

## 9.4. Regular maintenance

### Regular maintenance for 960 h (3 months)

The following check and repair items shall be done for manipulator after the 960h or 3 months (whichever comes first). As shown in Table 9-3.

Table 9-3 Maintenance Items for 960 h (3 months)

No.	Check Item	Essentials
1	Cleaning of control cabinet vent	Remove the dust accumulated at control cabinet vent
2	Cleaning of manipulator	Wipe off the dirt and remove the accumulated splash, dust, chip, etc.

### Regular maintenance for 1,920 h (6 months)

The following check and repair items shall be done for manipulator after the 1,920 h or 6 months (whichever comes first). As shown in Table 9-4.

Table 9-4 Maintenance Items for 1,920 h (6 months)

No.	Check Item	Essentials
1	Check whether the manipulator cable and cable sheath are damaged	See the first maintenance in <i>Chapter 9.3</i>
2	Whether the timing belt is worn out.	Check the synchronous belt for wear, elongation and breakage

### Regular maintenance for 3,840 h (1 year)

The following check and repair items shall be done for manipulator after the 3,840h or 1 year (whichever comes first). As shown in Table 9-5:

Table 9-5 Maintenance Items for 3,840 h (1 year)

No.	Check Item	Essentials
1	Check whether the manipulator cable and cable sheath are damaged	See the first maintenance in <i>Chapter 9.3</i>

No.	Check Item	Essentials
2	Tighten the main external bolts	See the first maintenance in <i>Chapter 9.3</i>
3	Clean all parts of the manipulator	See the first maintenance in <i>Chapter 9.3</i>
4	Whether the end effector cable is damaged	See the first maintenance in <i>Chapter 9.3</i>
5	Replace timing belt	See the first maintenance in <i>Chapter 9.3</i>
6	Check whether the J1 axis limit rubber block is damaged	See the first maintenance in <i>Chapter 9.3</i>

### Regular maintenance for 7,860 h (2 years)

The following check and repair items shall be done for manipulator after the 7,860h or 2 years (whichever comes first).

As shown in Table 9-6:

Table 9-6 Maintenance Items for 7,860 h (2 years)

No.	Check Item	Essentials
1	Battery Replacement	See <i>the first maintenance in Chapter 10.3</i>

### Regular maintenance for 11,520 h (3 years)

The following check and repair items shall be done for manipulator after the 11,520 h or 3 years (whichever comes first).

As shown in Table 9-7:

Table 9-7 Maintenance Items for 11,520 h (3 years)

No.	Check Item	Essentials
1	Replacement of synchronous belt	See <i>the first maintenance in Chapter 9.3</i>

### Regular maintenance for 15,360 h (4 years)

The following check and repair items shall be done for manipulator after the 15,360 h or 4 years (whichever comes first).

As shown in Table 9-8:

Table 9-8 Maintenance Items for 15,360 h (4 years)

No.	Check Item	Essentials
1	Replace the internal cables of manipulator	Replace the manipulator cable, please consult with us

### Regular maintenance for 19,200 h (5 year)

The manipulator shall be overhauled with many parts replaced for 5 years or 192,000 h (whichever comes first). Please contact us. As shown in Table 9-9:

Table 9-9 Maintenance Items for 19,200 h (5 years)

No.	Check Item	Essentials
1	Manipulator overhaul	Please consult with us

## 10. Project maintenance process

### 10.1. Cleaning the manipulator

In order to ensure the long-term operation of the robot, the manipulator should be cleaned regularly every 960 hours or 3 months of operation (whichever is shorter).

Cleaning steps:

- Step1. Adjust the robot to calibration state, refer to Figure 6-3.
- Step2. To prevent danger, turn off the power, hydraulic and air pressure sources connected to the robot.
- Step3. Use a vacuum cleaner to clean the manipulator, or wipe with a cloth.
- Step4. After ensuring that all safety conditions are met, proceed with the follow-up work of the manipulator.

 Caution	<ul style="list-style-type: none"> <li>■ It is forbidden to use water jet on the manipulator, especially the joints and seals.</li> <li>■ It is forbidden to use compressed air to clean the manipulator.</li> <li>■ It is forbidden to remove any manipulator protection device</li> <li>■ Do not use solvents to clean the manipulator</li> </ul>
----------------------------------------------------------------------------------------------	-----------------------------------------------------------------------------------------------------------------------------------------------------------------------------------------------------------------------------------------------------------------------------------------------------------------------------------------------------

### 10.2. Check and repair cables

In order to ensure that the robot can operate for a long time, the manipulator cables should be checked every 1920 hours or 6 months (whichever is shorter). The cable layout is shown in Figure 10-1.

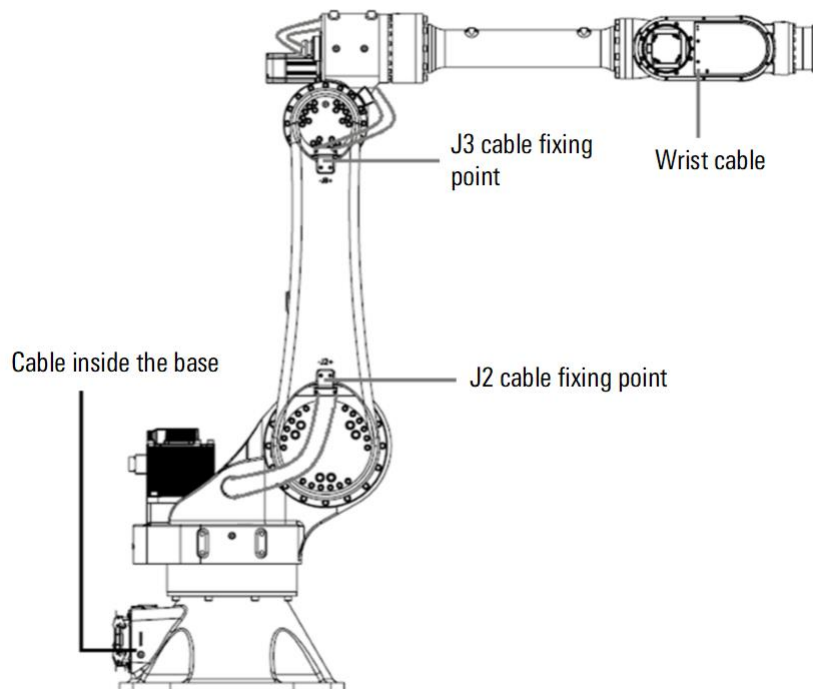

Figure 10-1 Manipulator cable layout diagram

## Repair external cables

Maintenance process:

- Step1. Adjust robot J1 to J6 axes to 0°, 0°, 90°, -180°, 0°, and 0°.
- Step2. To prevent danger, turn off the power, hydraulic source, and air source connected to the manipulator.
- Step3. Inspect all external cables with the naked eye for any signs of wear or damage.
- Step4. Check all cable connectors for integrity.
- Step5. Check that all brackets and straps are securely fastened to the manipulator.
- Step6. Check if there is any wear or damage at the cable and bracket fixing point.
- Step7. If there are cracks, wear or damage, please contact our company for replacement in a timely manner.

## Repair the internal cables of the base

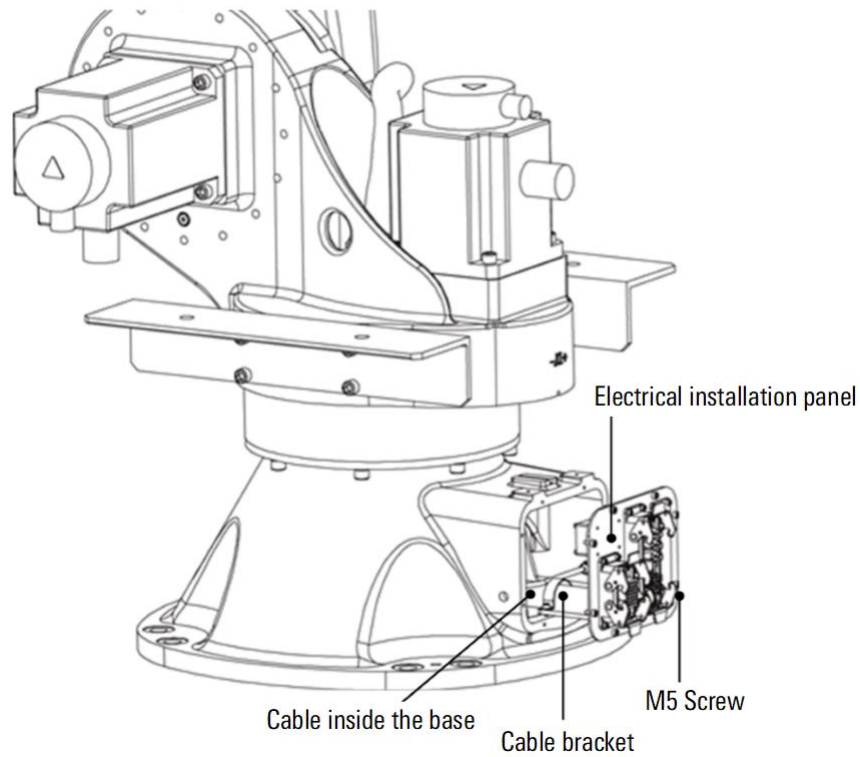

Figure 10-2 Diagram of cable composition inside the base

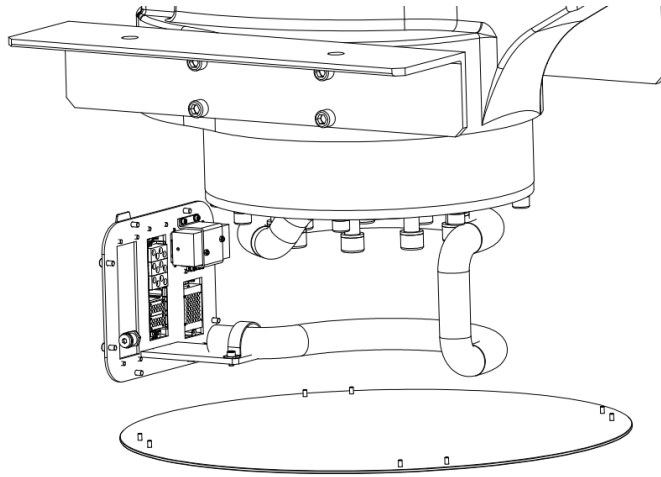

Figure 10-3 Diagram of cable routing inside the base

Maintenance process:

- Step1. Remove the electrical installation board, as shown in Figure 10-3, and pull out the cables inside the base.
- Step2. Check whether the cable bracket secures the cable to the manipulator intact.
- Step3. Check whether there is wear or damage where the cable and cable bracket are fixed.
- Step4. Check if there is any wear or damage to the internal cables.
- Step5. If there are cracks, wear or damage, please contact our company for replacement in a timely manner.
- Step6. Check if the lubricating grease on the surface of the internal cables has disappeared.
- Step7. If the surface lubricant of the cable disappears, it should be promptly replenished by applying lubricant to the surface of the cable.
- Step8. Insert the cable into the base, keeping it in the 'U' shape as shown in Figure 10-3.
- Step9. Install the electrical installation board and apply sealant on the joint surface between the electrical installation board and the base casting.

### Maintenance of internal cables in the wrist

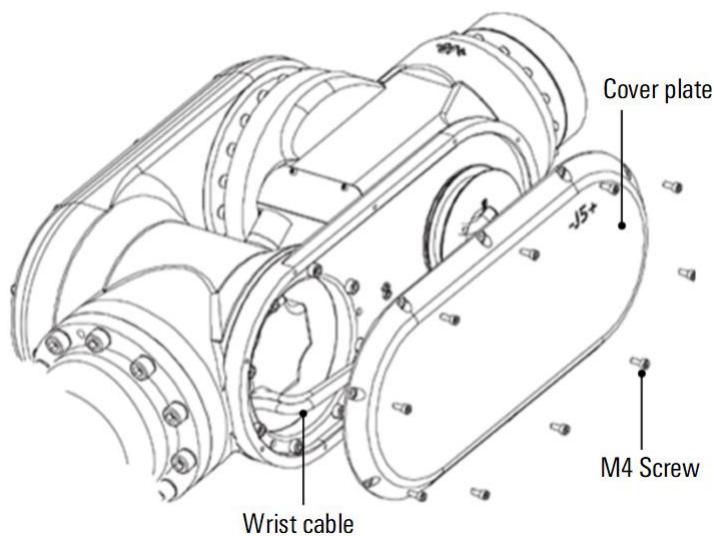

Figure 10-4 Wrist internal cable

Maintenance process:

- Step1. Remove the M4 screws on the cover plate and take off the cover plate, as shown in Figure 10-4.
- Step2. Check for any wear or damage at the cable and cable reel attachment point.
- Step3. Check if there is any wear or damage to the internal cables.
- Step4. If there are cracks, wear or damage, please contact our company for replacement in a timely manner.
- Step5. Check if the lubricating grease on the surface of the internal cables has disappeared.
- Step6. If the surface lubricant of the cable disappears, it should be replenished in a timely manner.
- Step7. Install the cover plate and apply sealant on the joint surface between the cover plate and the forearm.



Please entrust our service department with the task of replacing internal cables of the manipulator; using unqualified cables may cause the robot to malfunction.

### 10.3. Replacing the battery

The position data of each axis of the manipulator is saved by the encoder battery. The battery should be replaced promptly every 7860 hours or 2 years (whichever is shorter) of operation.

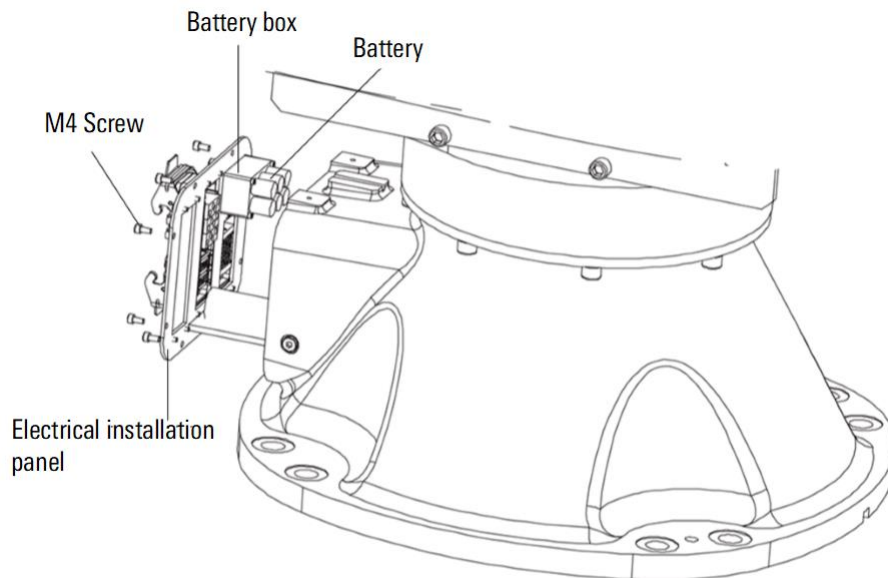

Figure 10-5 Diagram of disassembling and installing electrical control panel

Maintenance process:

- Step1. Adjust the robot to the calibration state.
- Step2. To prevent danger, turn off the power, hydraulic source, and air source connected to the robot.
- Step3. Remove the M4 screws, remove the operation electrical installation board, and dismantle the battery box, as shown in Figure 10-5.
- Step4. Remove the old battery from the battery compartment and insert the new battery into the battery compartment, paying attention to the polarity of the battery.



- Step5. Reconnect the battery cables.
- Step6. Install the battery box.
- Step7. Install the electrical installation board and apply sealant on the joint surface between the electrical installation board and the base casting.
- Step8. After ensuring that all safety conditions are met, proceed with the operation manipulator and testing work.

### 10.4. Replace the lubricating grease.

The internal lubricant needs to be replaced for the J1 to J6 axis reducer after running for 11,520 hours or 3 years (whichever comes first).

For the lubricating grease model and lubricating grease quantity, please refer to Table 10-1.

Table 10-1 Model and quantity of lubricating grease for manipulator

Manipulator model	Replace grease parts	Grease amount	Grease model
AIR75-2100B	J1 axis reducer	2823g	VIGOGREASE RE0
	J2 axis reducer	1572g	
	J3 axis reducer	1309g	
	J4 axis gearbox and reducer	1139g&589g	
	J5 axis reducer	268g	
	J6 axis reducer	190g	

When replacing grease, please refer to Table 10-2 for the manipulator posture.

Table 10-2 Grease replacement posture of manipulator

Replace grease parts	J1	J2	J3	J4	J5	J6
J1 axis reducer	0°	Any	Any	Any	Any	Any
J2 axis reducer	Any	0°	Any	Any	Any	Any
J3 axis reducer	Any	0°	90°	Any	Any	Any
J4 axis gearbox and reducer	Any	0°	90°	0°	Any	Any
J5 axis reducer	Any	0°	90°	0°	0°	Any
J6 axis reducer	Any	0°	90°	0°	0°	0°



Warning

- The reducer oil temperature may be higher than 90°, replace it after cooling.
- Wear gloves to prevent allergic reactions.
- Open the oil drain port carefully and slowly to prevent oil from splashing.

## J1 axis reducer grease replacement process

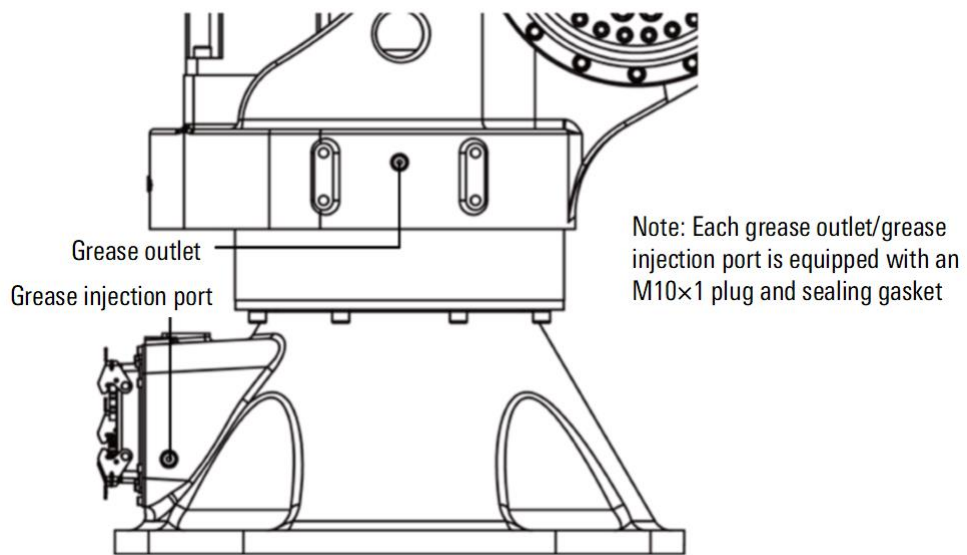

Figure 10-6 Replace J1 axis reducer grease

Maintenance process:

- Step1. Run the manipulator to the posture shown in Table 10-2.
- Step2. To prevent danger, turn off the power, hydraulic and pneumatic sources connected to the robot.
- Step3. Place the oil collection tank that collects waste oil near the grease drain.
- Step4. Remove the M10x1 plug and sealing gasket of the grease outlet, as shown in Figure 10-6.
- Step5. Install the oil pipe for draining grease to ensure that waste oil flows into the oil collection tank.
- Step6. Remove the M10x1 plug and sealing gasket of the grease port, install the grease nozzle, and use a manual grease gun to inject grease until the new grease is discharged from the grease outlet.
- Step7. Release the grease pressure inside the reducer as shown in Table 10-3.
- Step8. Weigh the amount of grease discharged and the amount of grease injected. They must be equal; if the discharge amount is less than the injection amount, inflate the grease injection port to discharge the excess amount; if the discharge amount is greater than the injection amount, just inject the missing amount from the grease injection port.
- Step9. Remove the grease nozzle from the grease injection port, install M10x1 plugs and sealing gaskets at the grease discharge port and grease injection port, and apply sealant with sealing tape.



Caution

When injecting grease from the grease injection port to the inside of the manipulator, use a manual pump to inject grease with a speed of less than 8g/s and a grease injection pressure of less than 0.3MPa. In order to ensure that the old oil inside the reducer is smoothly discharged, after filling the oil for a period of time, rest for a while, and then continue filling the oil when there is no old grease discharged from the oil outlet. When the oil injection speed is too fast, the instantaneous pressure inside the reducer will become high. As a result, the grease may cause damage to the motor oil seal and the grease may enter the inside of the motor.

## J2 axis reducer grease replacement process

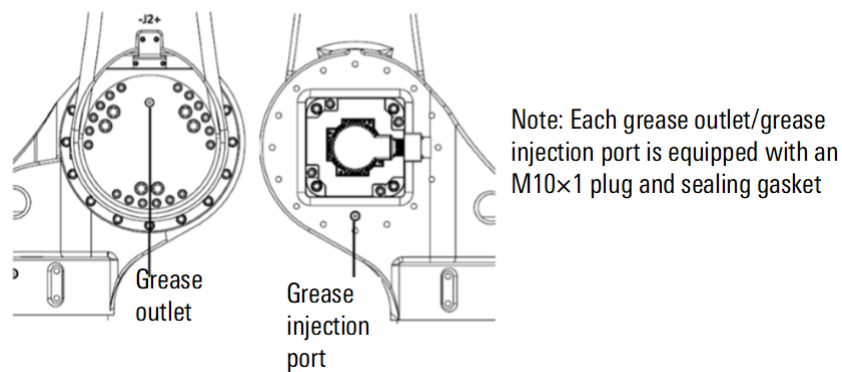

Figure 10-7 Replace the J2 axis reducer grease

Maintenance process:

- Step1. Run the manipulator to the posture shown in Table 10-2.
- Step2. To prevent danger, turn off the power, hydraulic and pneumatic sources connected to the robot.
- Step3. Place the oil collection tank that collects waste oil near the grease drain.
- Step4. Remove the M10x1 plug and sealing gasket of the grease outlet, as shown in Figure 10-7.
- Step5. Install the oil pipe for draining grease to ensure that waste oil flows into the oil collection tank.
- Step6. Remove the M10x1 plug and sealing gasket of the grease port, install the grease nozzle, and use a manual grease gun to inject grease until the new grease is discharged from the grease outlet.
- Step7. Release the grease pressure inside the reducer as shown in Table 10-3.
- Step8. Weigh the amount of grease discharged and the amount of grease injected. The two must be equal; if the discharge amount is less than the injection amount, inflate the grease injection port to discharge the excess amount; if the discharge amount is greater than the injection amount, just inject the missing amount from the grease discharge port.
- Step9. Remove the grease nozzle from the grease injection port, install M10x1 plugs and sealing gaskets at the grease discharge port and grease injection port, and apply sealant with sealing tape.



Caution

When injecting grease from the grease injection port to the inside of the manipulator, use a manual pump to inject grease with a speed of less than 8g/s and a grease injection pressure of less than 0.3MPa. In order to ensure that the old oil inside the reducer is smoothly discharged, after filling the oil for a period of time, rest for a while, and then continue filling the oil when there is no old grease discharged from the oil outlet. When the oil injection speed is too fast, the instantaneous pressure inside the reducer will become high. As a result, the grease may cause damage to the motor oil seal and the grease may enter the inside of the motor.

## J3 axis reducer grease replacement process

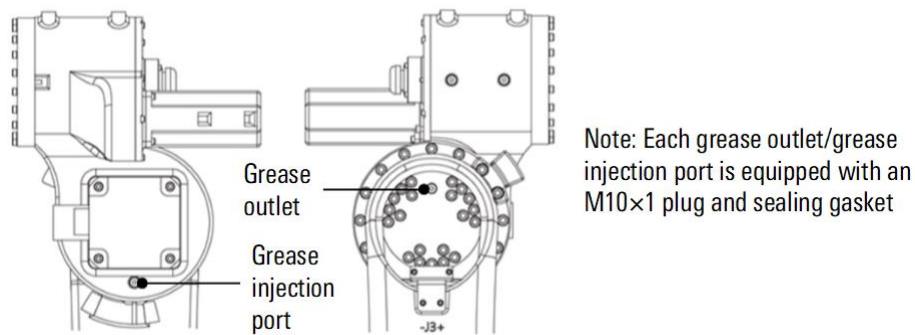

Figure 10-8 Replace the J3 axis reducer grease

## Maintenance process:

- Step1. Run the manipulator to the posture shown in Table 10-2.
- Step2. To prevent danger, turn off the power, hydraulic and pneumatic sources connected to the robot.
- Step3. Place the oil collection tank that collects waste oil near the grease drain.
- Step4. Remove the M10x1 plug and sealing gasket of the grease outlet, as shown in Figure 10-8.
- Step5. Install the oil pipe for draining grease to ensure that waste oil flows into the oil collection tank.
- Step6. Remove the M10x1 plug and sealing gasket of the grease port, install the grease nozzle, and use a manual grease gun to inject grease until the new grease is discharged from the grease outlet.
- Step7. Release the grease pressure inside the reducer as shown in Table 10-3.
- Step8. Weigh the amount of grease discharged and the amount of grease injected. The two must be equal; if the discharge amount is less than the injection amount, inflate the grease injection port to discharge the excess amount; if the discharge amount is greater than the injection amount, just inject the missing amount from the grease discharge port.
- Step9. Remove the grease nozzle from the grease injection port, install M10x1 plugs and sealing gaskets at the grease discharge port and grease injection port, and apply sealant with sealing tape.



Caution

When injecting grease from the grease injection port to the inside of the manipulator, use a manual pump to inject grease with a speed of less than 8g/s and a grease injection pressure of less than 0.3MPa. In order to ensure that the old oil inside the reducer is smoothly discharged, after filling the oil for a period of time, rest for a while, and then continue filling the oil when there is no old grease discharged from the oil outlet. When the oil injection speed is too fast, the instantaneous pressure inside the reducer will become high. As a result, the grease may cause damage to the motor oil seal and the grease may enter the inside of the motor.

## Lubrication grease replacement process for J4 axis gearbox and reducer

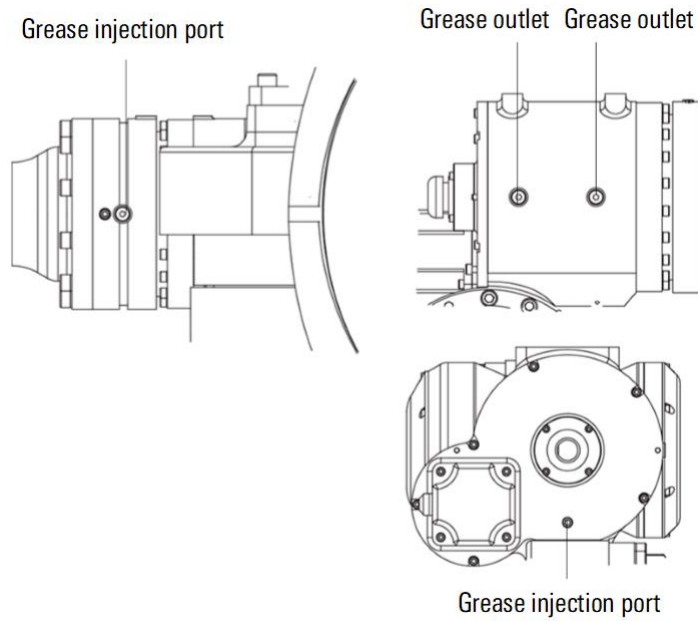

Figure 10-9 Diagram of replacing lubricating grease for J4 axis gearbox and reducer

Maintenance process:

- Step1. Run the manipulator to achieve the posture shown in Table 10-2.
- Step2. Cut off the power supply to the control device.
- Step3. Remove the sealing screw of the grease injection port and the grease discharge port, as shown in Figure 10-9.
- Step4. Supply grease from the grease injection port until the specified amount of new lubricating grease is added.
- Step5. Install the sealing screw for the grease outlet and apply sealant.

## J5 axis reducer grease replacement process

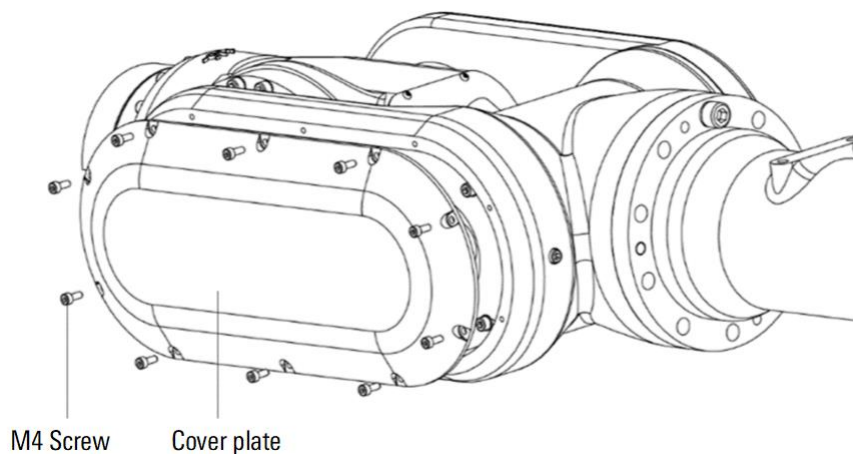

Figure 10-10 Remove the left cover plate

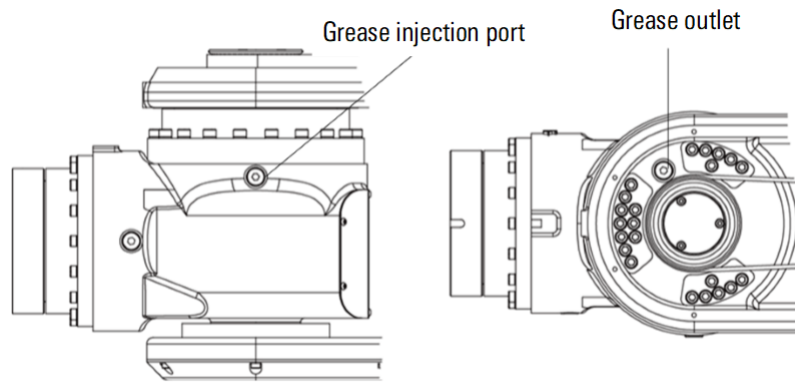

Figure 10-11 Replace the J5 axis reducer lubricating grease

Maintenance process:

- Step1. Run the manipulator to achieve the posture shown in Table 10-2.
- Step2. Cut off the power supply to the control device.
- Step3. Remove the M4 screws from the left sealing cover, as shown in Figure 10-10.
- Step4. Remove the sealing screw of the grease injection port and the grease discharge port, as shown in Figure 10-11.
- Step5. Supply grease from the grease injection port until the specified amount of new lubricating grease is added.
- Step6. Install the sealing cover and apply sealant to the contact surface.

#### J6 axis reducer grease replacement process

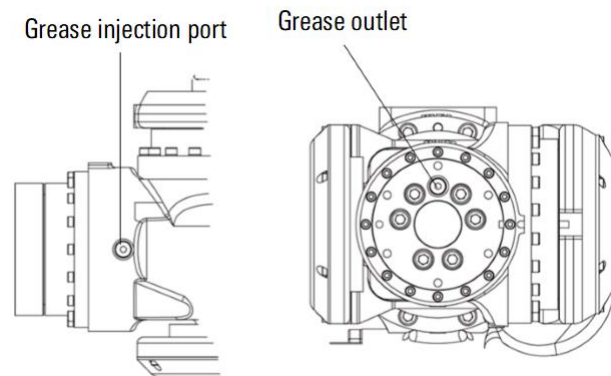

Figure 10-12 Replace the J6 axis reducer lubricating grease

Maintenance process:

- Step1. Run the manipulator to achieve the posture shown in Table 10-2.
- Step2. Cut off the power supply to the control device.
- Step3. Remove the sealing screw of the grease injection port and the grease discharge port, as shown in Figure 10-12.
- Step4. Supply grease from the grease injection port until the specified amount of new lubricating grease is added.
- Step5. Install the sealing cover and apply sealant to the contact surface.

#### Release the internal grease pressure of the reducer

When releasing the internal lubricating grease pressure of the reducer, please install a recycling device at the grease discharge port to avoid splashing out lubricating grease and polluting the environment.

Table 10-3 Release the internal pressure of the reducer and gearbox

Replace the lubricating grease part	Action angle	Action time	Precondition
J1 axis reducer	>90°	10 minutes	Install a plug or nozzle for the grease injection port, and do not install sealing screws for the grease discharge port
J2 axis reducer	>90°	10 minutes	
J3 axis reducer	>90°	10 minutes	



Caution

When performing incorrect grease supply operations, it may cause a sharp increase in pressure in the reducer or gearbox, damage internal parts such as sealing rings, and ultimately lead to oil leakage or poor operation. Be sure to follow the following precautions:

- Before supplying grease, be sure to remove the sealing screw of the grease outlet.
- Use a manual pump to slowly supply the grease.
- Be sure to use the specified lubricating grease.
- After supplying the grease, release the internal pressure according to the steps in Table 10-3 and install the sealing screw.
- Thoroughly wipe off the lubricating grease stuck to the floor and the operator to avoid slipping.

## 10.5. Replace timing belt

The J5 axis synchronous belt needs to be replaced every 11520 hours or 3 years of operation (whichever is shorter). For synchronous belt models, see Table 10-4.

Table 10-4 Manipulator synchronous belt model

Manipulator model	Synchronous belt position	Synchronous belt model
AIR75-2100B	J5 axis synchronous belt	GATES, 600-5MGT-15

When replacing the synchronous belt, refer to Table 10-5 for the posture of the manipulator.

Table 10-5 Replacing the synchronous belt posture of the manipulator

J1	J2	J3	J4	J5	J6
Arbitrarily	0°	90°	0°	90°	Arbitrarily

### Replace the J5 axis synchronous belt

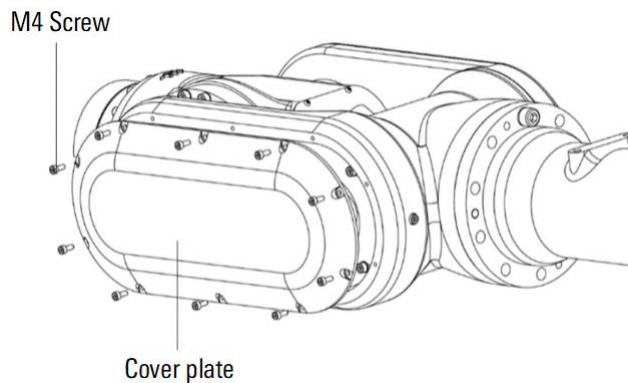

Figure 10-13 Remove the cover plate

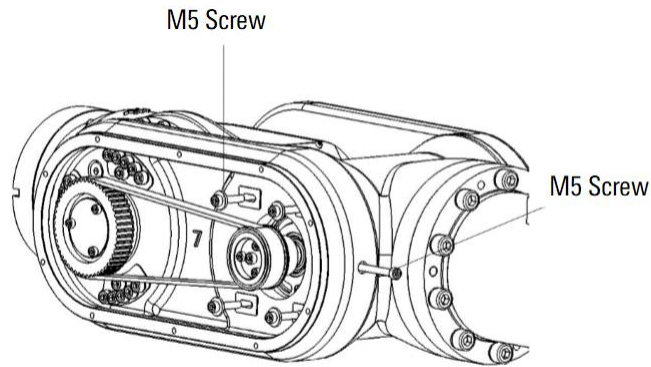

Figure 10-14 Removing the J5 motor flange

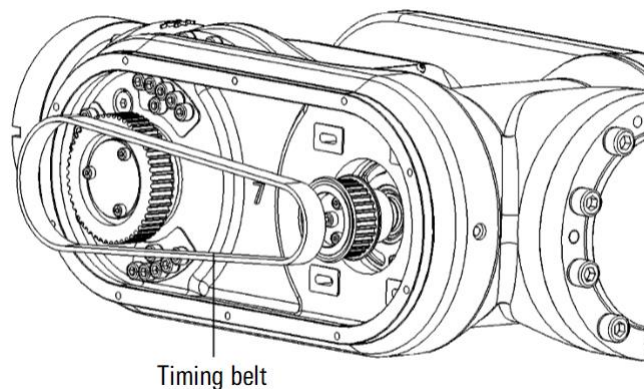

Figure 10-15 Removing synchronous belt

Maintenance process:

- Step1. Run the manipulator to the posture shown in Table 10-5.
- Step2. Cut off the power supply to the control device.
- Step3. Remove the left manipulator cover plate and use an Allen wrench to remove 8 M4 screws, as shown in Figure 10-13.
- Step4. Loosen the timing belt adjustment screw.
- Step5. Remove the tension screw, then remove the J5 motor flange screw and pulley adjustment screw, and use an external hexagonal wrench to remove the M5 screw, as shown in Figure 10-14.
- Step6. Reduce the distance between the two pulleys, remove the old timing belt, and then install the new timing belt, as shown in Figure 10-15.
- Step7. Preliminary installation of motor base screws M5.
- Step8. Install the adjusting screw with an Allen wrench and adjust the synchronous belt to the appropriate tension; Synchronous belt frequency 93-97.4Hz.
- Step9. Install the motor base screw M5 using the specified torque.
- Step10. Install the manipulator cover plate and apply sealant to the joint.
- Step11. Perform calibration work on the J5 axis of the manipulator.





Warning

After replacing the synchronous belt, the calibration of the J5 axis of the manipulator should be carried out. Please refer to "6.2.2 Calibration positions of each axis" in this manual for details.



# 11. Fault finding, diagnosis and repair

The malfunction of the manipulator is sometimes caused by multiple different reasons. It is often difficult to thoroughly investigate the cause. If the error handling method is adopted, the malfunction may be further deteriorated. Therefore, it is very important to analyze the malfunction in detail and find the real cause.

The possible faults and causes of the manipulator are shown in Table 11-1-Table 11-7. If you are not sure of the cause or how to deal with it, please contact our company.

Table 11-1 Possible faults and causes of manipulator

Fault	Classification	Possible Causes	Treatment
Vibration Abnormal noise	<ul style="list-style-type: none"> <li>■ When the manipulator operates, its base floats from the workshop pedestal</li> <li>■ There is a gap between the base and workshop pedestal</li> <li>■ The screws connecting the base and workshop pedestal are loose</li> </ul>	<p>Fixation of Base:</p> <ol style="list-style-type: none"> <li>1. The manipulator base is not firmly fixed on the workshop pedestal</li> <li>2. The base floats from the workshop pedestal and generates the vibration when the manipulator acts due to the screw looseness, insufficient flatness of base and the foreign objects.</li> </ol>	<ol style="list-style-type: none"> <li>1. When the screw is loose, tighten it with the torque wrench according to the proper torque</li> <li>2. Trim the base flatness in accordance with the tolerance</li> <li>3. Check if the foreign matters are trapped, and if so, remove them</li> <li>4. Please consult with us</li> </ol>
	Workshop pedestal vibrates when the manipulator acts	<p>Workshop Pedestal:</p> <ol style="list-style-type: none"> <li>1. Pedestal is not completely fixed on the foundation. Therefore, the workshop pedestal vibrates when the manipulator acts.</li> <li>2. The insufficient rigidity of workshop pedestal, and the reaction force and torque generated by the manipulator cause the deformation and vibration.</li> </ol>	<ol style="list-style-type: none"> <li>1. Completely fix the workshop pedestal according to the corresponding method</li> <li>2. Workshop pedestal shall be processed to improve its rigidity</li> <li>3. For the workshop pedestal with machining difficulty, the vibration may be mitigated through the modification of moving program</li> <li>4. Please consult with us</li> </ol>

Table 11-2 Possible Faults and Causes of Manipulator

Fault	Classification	Possible Causes	Treatment
Vibration Abnormal noise	<ul style="list-style-type: none"> <li>■ Vibration at a specific posture during the action</li> <li>■ No vibration at the slow action</li> <li>■ Obvious vibration during acceleration and deceleration</li> <li>■ Simultaneous vibration of multiple axes</li> </ul>	<ol style="list-style-type: none"> <li>1. Load of manipulator exceeds the allowable value</li> <li>2. Action procedures are too strict on the manipulator</li> <li>3. Improper acceleration</li> </ol>	<ol style="list-style-type: none"> <li>1. Confirm whether the manipulator load exceeds the allowable value, and reduce the load or change the action procedures</li> <li>2. Mitigate the specific vibrations by reducing speed, reducing acceleration and changing the action procedures</li> </ol>
	<ul style="list-style-type: none"> <li>■ Collision or long-term overload operation of manipulator</li> <li>■ No replacement of lubricating grease for a long time</li> </ul>	<ol style="list-style-type: none"> <li>1. Mechanical transmission system is subjected to excessive external force due to collision or overload, causing the damage to the gear surface or rolling surface of the gear, bearing, reducer or the peeling due to fatigue</li> <li>2. The gear surfaces or rolling surfaces of gear, bearing and reducer are damaged due to the foreign matters trapped in the gear, bearing or reducer.</li> <li>3. The gear surfaces or rolling surfaces of gear, bearing and reducer peel off due to fatigue because of no replacement of lubricating grease for long term</li> <li>4. The above reasons may cause the periodic vibration or abnormal noise</li> </ol>	<ol style="list-style-type: none"> <li>1. Make the manipulator operate uniaxially to confirm the Joint that produces the vibration and noise</li> <li>2. If you need to replace the gear, bearing and reducer, please contact us.</li> <li>3. Do not use the manipulator at overloaded status</li> <li>4. If you need to replace the lubricating grease, please contact us.</li> <li>5. Please consult with us</li> </ol>

Table 11-3 Possible Faults and Causes of Manipulator

Fault	Classification	Possible Causes	Treatment
<p>Vibration Abnormal noise</p>	<p>Causes may not be determined mechanically</p>	<ol style="list-style-type: none"> <li>1. Fault of the circuit inside the controller, failure of command to transmit to the motor, or the motor information not correctly transmitted to the controller</li> <li>2. Fault of pulse encoder and the position of motor not correctly transmitted to the controller</li> <li>3. Failure of motor body to perform its original functions</li> <li>4. Breakage of internal motor cable of manipulator causes the command not to be correctly transmitted to the motor and control system</li> <li>5. Voltage drop and no guarantee for the specified voltage</li> <li>6. Incorrect control parameters are input</li> </ol>	<ol style="list-style-type: none"> <li>1. For the fault of controller, see the controller manual</li> <li>2. Replace the motor of vibrating Joint to confirm whether it vibrates</li> <li>3. Check the cables of the manipulator body, between the manipulator body and control cabinet, and inside the controller for damage, and if so, replace the cable.</li> <li>4. Check whether the cable joint is in good contact. In case of the poor contact or looseness, re-tighten or take appropriate measures to ensure the good contact.</li> <li>5. Check whether the action control parameters are correct, and if not, re-enter the correct parameters.</li> <li>6. Please consult with us</li> </ol>
	<p>The mechanical action near the manipulator is closely related to the vibration of robot.</p>	<ol style="list-style-type: none"> <li>1. Mechanical electrical noise from the manipulator</li> <li>2. If the grounding wire is not connected properly, the electrical noise will mix into the grounding wire, causing the vibration of manipulator due to the interference with command</li> <li>3. Poor connection of grounding wire will lead to the unstable grounding, causing the vibration of manipulator due to electrical noise interference.</li> </ol>	<ol style="list-style-type: none"> <li>1. Connect the grounding wire properly to avoid the electrical noise mixed into the manipulator</li> <li>2. Please consult with us</li> </ol>

Table 11-4 Possible Faults and Causes of Manipulator

Fault	Classification	Possible Causes	Treatment
<p>Vibration Abnormal noise</p>	<ul style="list-style-type: none"> <li>■ Abnormal noise after the replacement of lubricating grease</li> <li>■ Abnormal noise occurs during the operation of robot after a long-term shutdown</li> <li>■ Abnormal noise at low speed</li> </ul>	<p>1. Abnormal noise from the manipulator at low speed immediately after the replacement or at the restart after the long-term shutdown.</p>	<p>1. Observe the operation of manipulator for 1-2 days. Usually the abnormal noise will disappear.</p>
<p>Shake of manipulator</p>	<ul style="list-style-type: none"> <li>■ After power-off, some parts of manipulator may be shaken manually.</li> <li>■ There is a gap between the connecting surfaces of manipulator</li> </ul>	<p>1. Manipulator bolts are loose 2. Connecting bolts on the manipulator are loose due to the overload, collision, etc., thus resulting in the shake</p>	<p>For each Joint, check if the bolts at the following parts are loose. If so, tighten it with a torque wrench according to a suitable torque.</p> <ol style="list-style-type: none"> <li>1. Fixing bolts of motor</li> <li>2. Fixing bolts of reducer shell</li> <li>3. Fixing bolts of output shaft of reducer</li> <li>4. Fixing bolts of pedestal</li> <li>5. Fixing bolts between arms</li> <li>6. Fixing bolts of shell</li> <li>7. Fixing bolts of end effector</li> </ol>
	<p>Turn off the power of manipulator, and confirm that the screws are tightened, and shake the entire head of manipulator manually</p>	<p>1. Large backlash is resulted from the wear or damage of internal gears of manipulator due to the overload, collision, etc.</p>	<p>1. If you need to replace the internal gear, please consult with us</p>

Table 11-5 Possible Faults and Causes of Manipulator

Fault	Classification	Possible Causes	Treatment
Motor overheating	<ul style="list-style-type: none"> <li>■ Ambient temperature rise for installation of manipulator, and the overheating of motor</li> <li>■ Motor overheats after the cover plate is mounted on the motor</li> <li>■ Motor overheats after the action procedures of manipulator and load conditions are changed</li> </ul>	<p>Ambient Temperature :</p> <ol style="list-style-type: none"> <li>1. Ambient temperature rise or the deterioration of heat dissipation of motor after the cover plate is installed</li> </ol> <p>Load Action:</p> <ol style="list-style-type: none"> <li>1. Current value of motor exceeds its rated value due to the load and operating procedures</li> </ol>	<ol style="list-style-type: none"> <li>1. Decrease of ambient temperature may prevent the motor from overheating</li> <li>2. Improvement of ventilation conditions around the motor, i.e. the heat dissipation of motor, may effectively prevent the motor from overheating.</li> <li>3. A radiation shielding plate if there is a heat source around the motor may prevent the motor from overheating.</li> <li>4. Slowing down the action procedures and reducing the load may decrease the average current value of motor, thus preventing the motor from overheating.</li> <li>5. Please consult with us</li> </ol>
	<p>Motor overheats after the action control parameters of manipulator are changed</p>	<p>Control Parameter:</p> <ol style="list-style-type: none"> <li>1. Improper input parameters will cause the incorrect acceleration and deceleration of robot, so that the average current value of increases.</li> </ol>	<ol style="list-style-type: none"> <li>1. Enter the appropriate parameters according to the relevant instructions.</li> <li>2. Please consult with us</li> </ol>
	<p>Motor overheats due to the causes other than above ones</p>	<p>Mechanical Fault of Manipulator:</p> <ol style="list-style-type: none"> <li>1. Mechanical system fault of manipulator causes the overload of motor</li> </ol> <p>Motor fault:</p> <ol style="list-style-type: none"> <li>1. Brake fault causes the motor to always operate when the brake is applied, which causes the motor to withstand excessive load</li> <li>2. Failure of motor body to perform its functions causes the excessive current to flow through the motor</li> </ol>	<ol style="list-style-type: none"> <li>1. Please rectify the mechanical fault by reference to the instructions of vibration, abnormal noise and looseness.</li> <li>2. Please confirm whether the brake is released when the motor is powered on.</li> <li>3. After the motor is replaced, the overheating of motor disappears. It is confirmed that the this condition is abnormal.</li> <li>4. Please consult with us</li> </ol>

Table 11-6 Possible Faults and Causes of Manipulator

Fault	Classification	Possible Causes	Treatment
Leakage of lubricating grease	Lubricating grease leaks out from the mechanical part	<p>Poor Sealing:</p> <ol style="list-style-type: none"> <li>1. Crack of casting due to the excessive external force caused by the collision</li> <li>2. Damage of O-ring during the disassembly and reassembly</li> <li>3. Scratch of oil seal due to the dust intrusion</li> <li>4. Poor sealing between the cover plate and casting</li> </ol>	<ol style="list-style-type: none"> <li>1. In case of casting crack, etc., the sealant may be used to block the lubricating grease as an emergency measure, but in view of the further extension of crack, the part shall be replaced as soon as possible.</li> <li>2. Please consult with us</li> </ol>
Falling of manipulator axis	<ul style="list-style-type: none"> <li>■ The brake is completely ineffective and the Joint falls quickly</li> <li>■ After the brake is contracted, the shaft falls slowly</li> </ul>	<ol style="list-style-type: none"> <li>1. The damage of brake drive relay causes the brake to always be powered on and not to work.</li> <li>2. Wear and damage of brake body affect the braking effect.</li> <li>3. The lubricating oil and grease inside the motor cause the brake to slip.</li> </ol>	<ol style="list-style-type: none"> <li>1. Check if the brake drive relay is damaged, and if so, replace the relay</li> <li>2. In case of the wear of brake, the damage of brake body and the lubricating grease inside the motor, replace the motor.</li> <li>3. Please consult with us</li> </ol>

Table 11-7 Possible Faults and Causes of Manipulator

Fault	Classification	Possible Causes	Treatment
Position offset	<ul style="list-style-type: none"> <li>■ Manipulator deviates from the teaching position</li> <li>■ The repeated positioning accuracy of manipulator is greater than the allowed value</li> </ul>	<p>Mechanical Fault:</p> <ol style="list-style-type: none"> <li>1. The unstable repeated positioning accuracy may be caused by the mechanical system abnormality, screw looseness, etc.</li> <li>2. The repeated positioning accuracy keeps stable after the deviation; the joint surface of pedestal surface, Joint casting and reducer may slide due to the excessive load such as the collision.</li> <li>3. Abnormality of motor encoder</li> </ol>	<ol style="list-style-type: none"> <li>1. In case of the unstable repeated positioning accuracy, please rectify the mechanical fault by reference to the instructions for the vibration, abnormal noise and shaking.</li> <li>2. If the repeated positioning accuracy keeps stable, please modify the teaching program. If the collision does not occur again, the deviation may be avoided.</li> <li>3. In case of the abnormality of motor encoder, replace the motor or encoder.</li> </ol>



Fault	Classification	Possible Causes	Treatment
			4. Please consult with us
	Position only deviates from the specific peripheral equipment	Deviation of Peripheral Equipment 1. The external equipment under the external force leads to the deviation relative to the manipulator	1. Please relocate the peripheral equipment 2. Please modify the teaching program 3. Please consult with us
	Deviation occurs after the modification of parameters	Parameters: 1. The modification of calibration data causes the loss of manipulator origin	1. Re-enter the previous correct calibration data 2. In case of uncertain calibration data, please recalibrate the manipulator 3. Please consult with us



## Appendix A AIR75-2100B type manipulator regular maintenance table

Appendix A Periodic Maintenance Schedule of AIR75-2100B Manipulator

Item	Mainten ance cycle	First Maintenance 320h	3 months 960h	6 months 1,920h	9 months 2,880h	1 year 3,840h	15 months 4,800h	18 months 5,760h	21 months 6,720h	2 years 7,680h	27 months 8,640h	30 months 9,600h	33 months 10,560h	3 years 11,520h	39 months 12,480h	42 months 13,440h	45 months 14,400h	4 years 15,360h	51 months 16,320h	54 months 17,280h	57 months 18,240h	5 years 19,200h
1	Cleaning of manipulator	0.5h	○	○	○	○	○	○	○	○	○	○	○	○	○	○	○	○	○	○	○	○
2	Cleaning of control cabinet vent	0.1h	○	○	○	○	○	○	○	○	○	○	○	○	○	○	○	○	○	○	○	○
3	Wether the synchronous belt worn	0.5h	○	○	○	○	○	○	○	○	○	○	○	○	○	○	○	○	○	○	○	○
4	Check the manipulator cable for damage	3h	○	○	○	○	○	○	○	○	○	○	○	○	○	○	○	○	○	○	○	○
5	Check the manipulator cable sheath for damage	2h	○	○	○	○	○	○	○	○	○	○	○	○	○	○	○	○	○	○	○	○
6	Check the connecting cable of teach pendant, control cabinet and manipulator for damage	0.2h	○	○	○	○	○	○	○	○	○	○	○	○	○	○	○	○	○	○	○	○

Item	Mainten ance cycle	First Maintenance 320h	3 months 960h	6 months 1,920h	9 months 2,880h	1 year 3,840h	15 months 4,800h	18 months 5,760h	21 months 6,720h	2 years 7,680h	27 months 8,640h	30 months 9,600h	33 months 10,560h	3 years 11,520h	39 months 12,480h	42 months 13,440h	45 months 14,400h	4 years 15,360h	51 months 16,320h	54 months 17,280h	57 months 18,240h	5 years 19,200h
7	Check the connectors of motor, etc. for looseness	0.2h	○			○				○				○				○				○
8	Tighten the end effector screws	0.2h	○			○				○				○				○				○
9	Tighten the external main screws	1h	○			○				○				○				○				○
10	Check the end effector cable for damage	0.2h	○			○				○				○				○				○
11	Check the limit rubber block for damage	0.1h	○			○				○				○				○				○
12	Replacement of Synchronous Belt	1h				○				○				○				○				○
13	Battery Replacement	0.5h								○								○				
14	Replace the internal cables of manipulator	8h																○				
15	Manipulator overhaul																					○

Item	Mainten ance cycle	First Maintenance	3 months	6 months	9 months	1 year 3,840h	15 months 4,800h	18 months 5,760h	21 months 6,720h	2 years 7,680h	27 months 8,640h	30 months 9,600h	33 months 10,560h	3 years 11,520h	39 months 12,480h	42 months 13,440h	45 months 14,400h	4 years 15,360h	51 months 16,320h	54 months 17,280h	57 months 18,240h	5 years 19,200h
------	-----------------------	----------------------	-------------	-------------	-------------	------------------	------------------------	------------------------	------------------------	----------------------	------------------------	------------------------	-------------------------	--------------------	-------------------------	-------------------------	-------------------------	--------------------	-------------------------	-------------------------	-------------------------	--------------------

Note: ○ indicates that maintenance is required



## Appendix B Table of screw strength and tightening torque (Nm)

---

Appendix B Table of screw strength and tightening torque (Nm)

Thread specification	Performance level		
	8.8 level	10.9 level	12.9 level
M2	0.35	0.48	0.56
M2.5	0.68	0.93	1.1
M3	1.2	1.6	2
M4	2.8	3.7	4.4
M5	5.6	7.5	9
M6	9.5	12.5	15
M8	23	31	36
M10	45	60	70
M12	78	104	125
M14	113	165	195
M16	195	250	305
M20	370	500	600



Prompt

- All screws must be tightened with proper torque.
- Except for the torque specified in the text, the corresponding tightening torque shall be selected according to the screw performance level.
- Remove foreign matters in screws and threaded holes.
- Torque for lightly lubricated screws.
- Screws shall be tightened evenly and symmetrically.
- According to the installation requirements of the reducer and other moving parts, apply thread adhesive to the engagement part of some screws.







WeChat Official  
Account



Official Website

Service Hotline : 400-990-0909

Official Website : <http://robot.peitian.com>

UM-P05310000103-001 / V1.0.1 / 2023.10.07

© 2011-2023 Peitian Robotics Co., Ltd. All right Reserved.

The description about the product characteristics and availability does not constitute a performance guarantee, and is reference only. The scope of services for the products delivered is subject to the specific contract.