



AIR75-2100

高速度
高精度
高稳定性
腕部 IP67

High speed
High precision
High stability
Wrist IP67

- 重复定位精度高达 $\pm 0.06\text{mm}$ 。
High position repeatability up to $\pm 0.06\text{mm}$.
- 配备内置气管与 I/O 线缆。
AIR75-2100 is equipped with the built-in gas pipe and I/O cable.
- 主要应用于上下料、打磨抛光、搬运、码垛等作业。
AIR75-2100 is mainly used in loading & unloading, grinding & polishing, handling, palletizing, etc.

型号 Type		AIR75-2100
轴数 Axes		6
负载 Payload		75kg
机器人本体 Manipulator	重量 Weight	530kg
	最大运动范围 Reach	2112mm
定位精度 Positioning accuracy	位置重复定位精度 Position repeatability	$\pm 0.06\text{mm}$
IP 等级 Ingress Protection		IP54 (腕部 : IP67) IP54 (Wrist : IP67)
安装方式 Mounting		地装 Floor
运动范围 Working range	轴 1* Axis 1 rotation	$-170^\circ/+170^\circ$
	轴 2 Axis 2 arm	$-75^\circ/+145^\circ$
	轴 3 Axis 3 arm	$-120^\circ/+170^\circ$
	轴 4 Axis 4 wrist	$-350^\circ/+350^\circ$
	轴 5 Axis 5 bend	$-120^\circ/+120^\circ$
	轴 6 Axis 6 turn	$-360^\circ/+360^\circ$
运动速度 Rotation rate	轴 1 Axis 1 rotation	177°/s
	轴 2 Axis 2 arm	178°/s
	轴 3 Axis 3 arm	173°/s
	轴 4 Axis 4 wrist	260°/s
	轴 5 Axis 5 bend	255°/s
	轴 6 Axis 6 turn	370°/s
适用控制柜 Controllers		ARC4-75
安装条件 Mounting conditions	环境温度: $0\sim 45^\circ\text{C}$ Ambient temperature: $0\sim 45^\circ\text{C}$ 湿度: 恒温下 95% 以内, 无凝露。 Humidity: not more than 95% at constant temperature without condensation. 允许高度: 操作机正常工作环境的海拔高度不应超过 1000 米 (在 1000 米 -4000 米高度范围内, 操作机应降额使用)。 Allowable altitude: not more than 1000m above sea level. 不应有腐蚀性、可燃性、易爆性气体。 No corrosive, flammable or explosive gases.	



* 若去除机械限位, 运动范围可达 $-180^\circ/+180^\circ$ 。
If the mechanical limit is removed, the working range can reach $-180^\circ/+180^\circ$.

外形尺寸及运动范围 Outline dimension and Working range

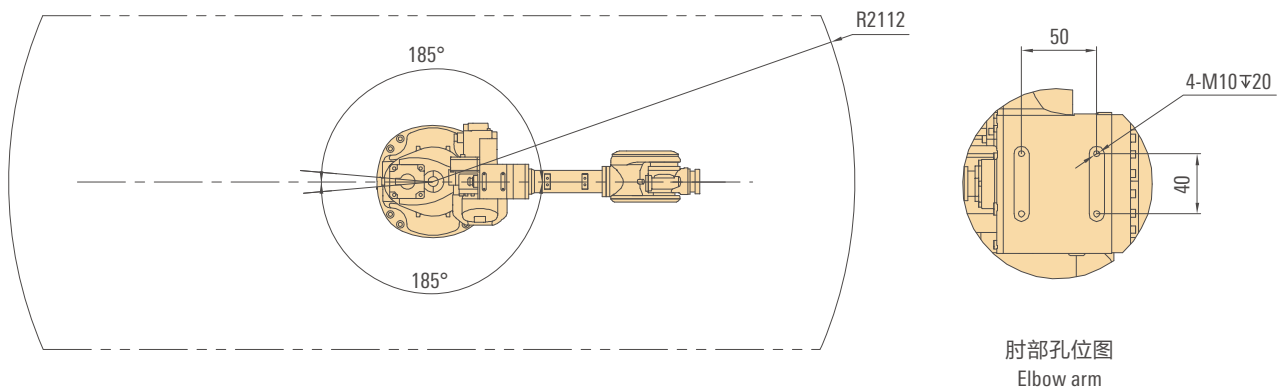
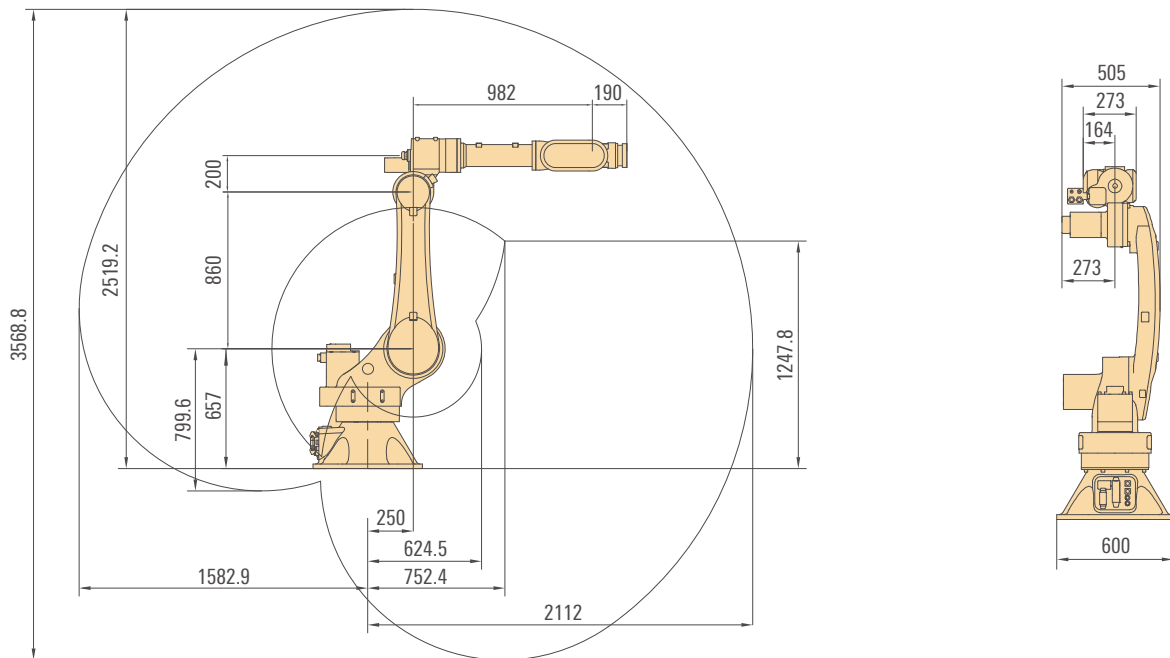

法兰图 Flange drawing

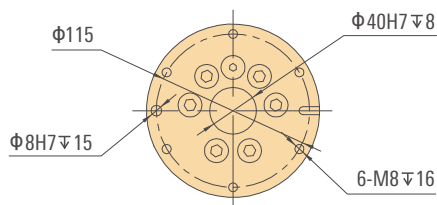

底座安装图 Base installation drawing

