



## AIR220-3100

大惯量  
高速度  
高稳定性

High inertia  
High speed  
High stability

- 大负载, 大惯量, 高刚性, 实现大尺寸、大偏心的负载的高速搬运。  
Large payload, high inertia and high rigidity ensure high-speed handling operation with large-sized, large-eccentric loads.
- 采用高速、高过载电机, 能量密度高, 力矩波动小, 运行更平稳。  
With higher energy density and smaller torque fluctuations, smoother operation can be achieved by using high-speed and high-overload motors.
- 内置气管和 IO 线束, 有效减少外挂线束对周边设备的干扰。  
Built-in air tubes and IO harness, effectively reduces the interference of external wiring harness to peripheral equipment.

型号 Type		AIR220-3100
轴数 Axes		6
负载 Payload		220kg
机器人本体 Manipulator	重量 Weight	1255kg
	最大运动范围 Reach	3104mm
定位精度 Positioning accuracy	位置重复定位精度 Position repeatability	±0.06mm
IP 等级 Ingress Protection		IP54 ( 腕部 : IP65 ) IP54 ( Wrist : IP65 )
安装方式 Mounting		地装 Floor
运动范围 Working range	轴 1 Axis 1 rotation	-180°/+180°
	轴 2 Axis 2 arm	-60°/+85°
	轴 3 Axis 3 arm	-110°/+170°
	轴 4 Axis 4 wrist	-200°/+200°
	轴 5 Axis 5 bend	-135°/+135°
	轴 6 Axis 6 turn	-360°/+360°
运动速度 Rotation rate	轴 1 Axis 1 rotation	120°/s
	轴 2 Axis 2 arm	100°/s
	轴 3 Axis 3 arm	100°/s
	轴 4 Axis 4 wrist	175°/s
	轴 5 Axis 5 bend	210°/s
	轴 6 Axis 6 turn	270°/s
适用控制柜 Controllers		ARC5-280
安装条件 Mounting conditions	环境温度: 0~45°C Ambient temperature: 0~45°C 湿度: 恒温下 95% 以内, 无凝露。 Humidity: not more than 95% at constant temperature without condensation. 允许高度: 操作机正常工作环境的海拔高度不应超过 1000 米 (在 1000 米 -4000 米高度范围内, 操作机应降额使用)。 Allowable altitude: not more than 1000m above sea level. 不应有腐蚀性、可燃性、易爆性气体。 No corrosive, flammable or explosive gases.	



外形尺寸及运动范围 Outline dimension and Working range

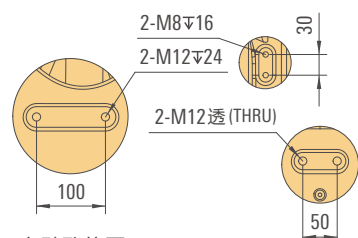
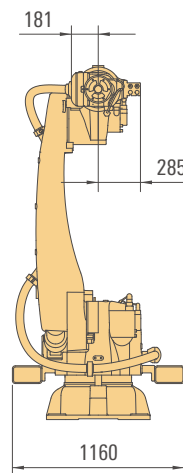
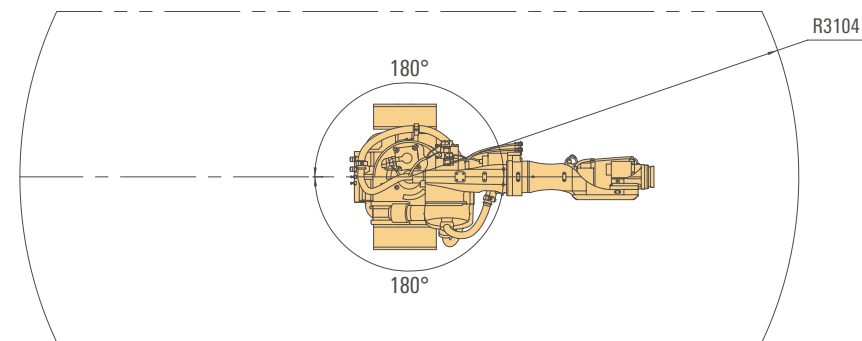
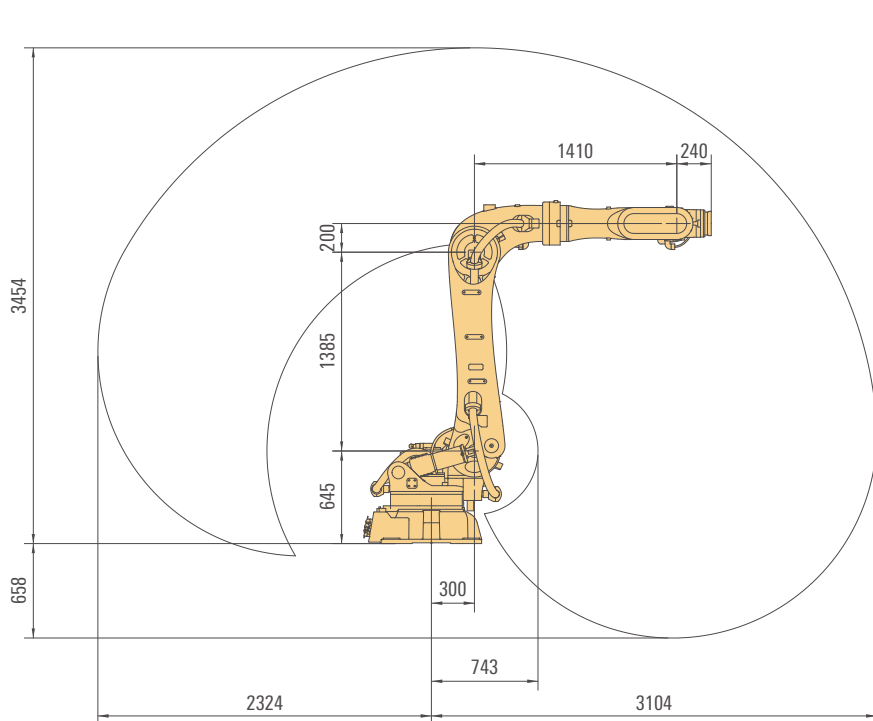

大臂孔位图  
Lower arm

小臂孔位图  
Upper arm

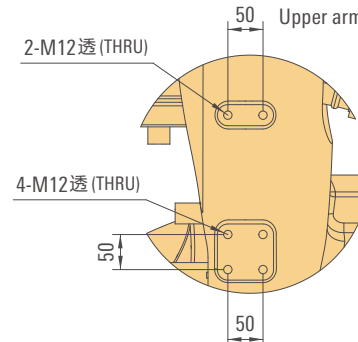

肘部孔位图  
Elbow arm

法兰图 Flange drawing

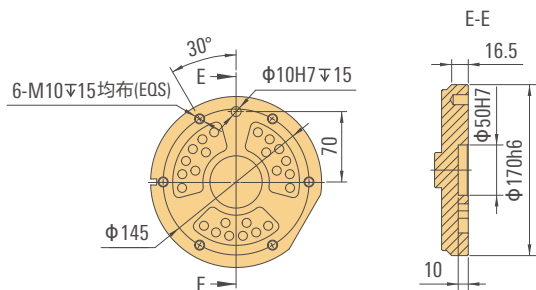

底座安装图 Base installation drawing

