



AIR220-2700

大惯量
高速度
高稳定性

High inertia
High speed
High stability

- 大负载, 大惯量, 高刚性, 实现大尺寸、大偏心的负载的高速搬运。
Large payload, high inertia and high rigidity ensure high-speed handling operation with large-sized, large-eccentric loads.
- 采用高速、高过载电机, 能量密度高, 力矩波动小, 运行更平稳。
With higher energy density and smaller torque fluctuations, smoother operation can be achieved by using high-speed and high-overload motors.
- 内置气管和 IO 线束, 有效减少外挂线束对周边设备的干扰。
Built-in air tubes and IO harness, effectively reduces the interference of external wiring harness to peripheral equipment.

型号 Type		AIR220-2700
轴数 Axes		6
负载 Payload		220kg
机器人本体 Manipulator	重量 Weight	1225kg
	最大运动范围 Reach	2707mm
定位精度 Positioning accuracy	位置重复定位精度 Position repeatability	±0.06mm
IP 等级 Ingress Protection		IP54 (腕部: IP65) IP54 (手腕: IP65)
安装方式 Mounting		地装 Floor
运动范围 Working range	轴 1 Axis 1 rotation	-180°/+180°
	轴 2 Axis 2 arm	-60°/+85°
	轴 3 Axis 3 arm	-110°/+170°
	轴 4 Axis 4 wrist	-200°/+200°
	轴 5 Axis 5 bend	-135°/+135°
	轴 6 Axis 6 turn	-360°/+360°
运动速度 Rotation rate	轴 1 Axis 1 rotation	120°/s
	轴 2 Axis 2 arm	114°/s
	轴 3 Axis 3 arm	114°/s
	轴 4 Axis 4 wrist	175°/s
	轴 5 Axis 5 bend	210°/s
	轴 6 Axis 6 turn	270°/s
适用控制柜 Controllers		ARC5-280
安装条件 Mounting conditions	环境温度: 0~45℃ Ambient temperature: 0~45℃ 湿度: 恒温下 95% 以内, 无凝露。 Humidity: not more than 95% at constant temperature without condensation. 允许高度: 操作机正常工作环境的海拔高度不应超过 1000 米 (在 1000 米 -4000 米高度范围内, 操作机应降额使用)。 Allowable altitude: not more than 1000m above sea level. 不应有腐蚀性、可燃性、易爆性气体。 No corrosive, flammable or explosive gases.	



外形尺寸及运动范围 Outline dimension and Working range

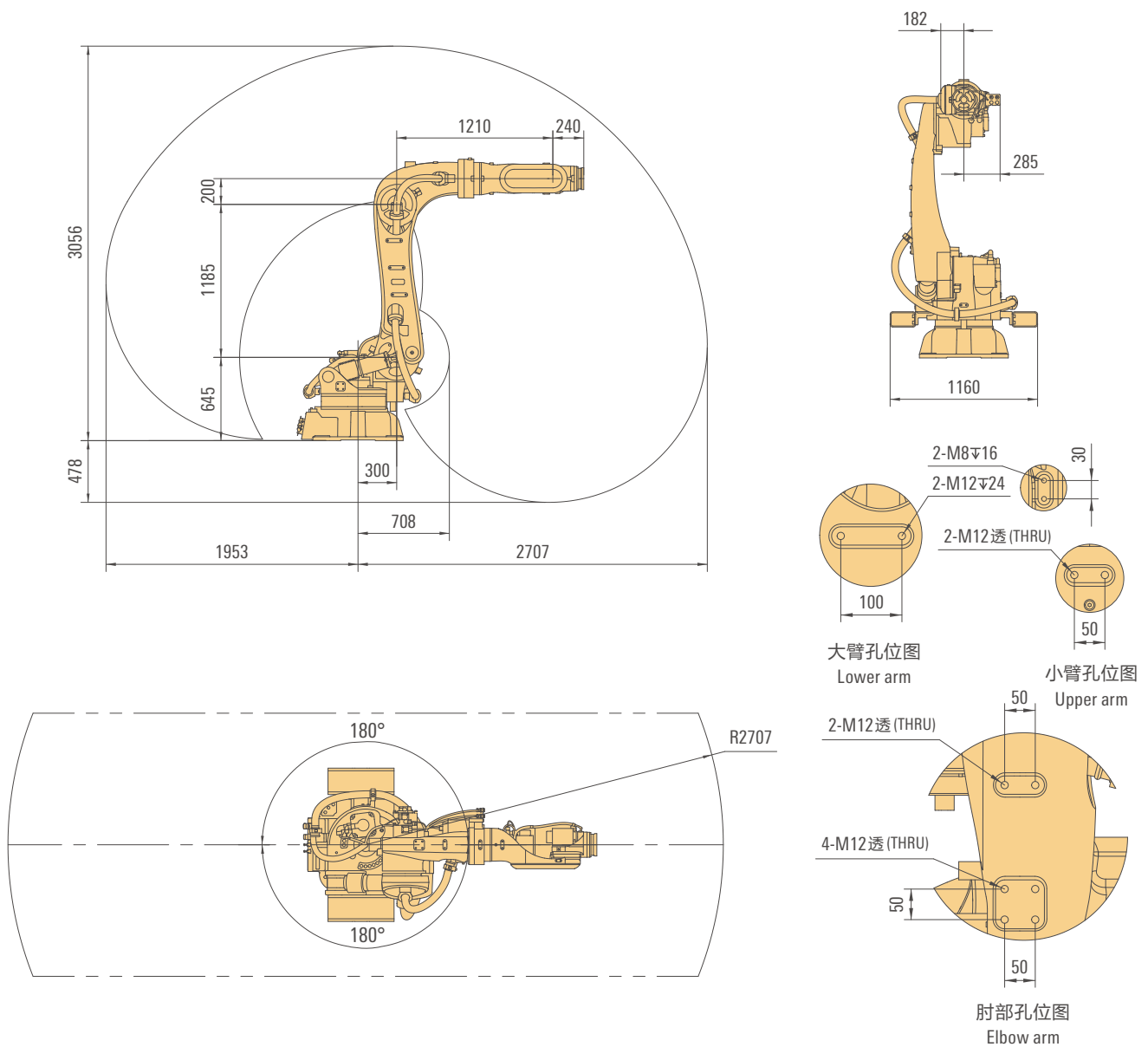

法兰图 Flange drawing

底座安装图 Base installation drawing

