



AIR20-2000

高速度	High speed
高精度	High precision
高稳定性	High stability
腕部 IP67, 高防护	Wrist IP67, high protection

- 外形流畅、结构紧凑。
Smooth appearance, compact structure.
- 高刚性有效抑制轨迹的抖动。
The high rigidity effectively inhibits the jitter of the trajectory.

型号 Type		AIR20-2000
轴数 Axes		6
负载 Payload		20kg
机器人本体 Manipulator	重量 Weight	280kg
	最大运动范围 Reach	2001mm
定位精度 Positioning accuracy	位置重复定位精度 Position repeatability	±0.03mm
	IP 等级 Ingress Protection	IP54 (腕部: IP67) IP54 (Wrist: IP67)
安装方式 Mounting		地装 / 壁装 / 吊装 Floor/ wall/ ceiling
运动范围 Working range	轴 1* Axis 1 rotation	-170°/+170°
	轴 2 Axis 2 arm	-95°/+155°
	轴 3 Axis 3 arm	-95°/+170°
	轴 4 Axis 4 wrist	-185°/+185°
	轴 5 Axis 5 bend	-135°/+135°
	轴 6 Axis 6 turn	-400°/+400°
运动速度 Rotation rate	轴 1 Axis 1 rotation	220°/s
	轴 2 Axis 2 arm	220°/s
	轴 3 Axis 3 arm	170°/s
	轴 4 Axis 4 wrist	375°/s
	轴 5 Axis 5 bend	465°/s
	轴 6 Axis 6 turn	755°/s
适用控制柜 Controllers		inCube22
安装条件 Mounting conditions	环境温度: 5~45℃ Ambient temperature: 5~45℃ 湿度: 恒温下 95% 以内, 无凝露。 Humidity: not more than 95% at constant temperature without condensation. 允许高度: 操作机正常工作环境的海拔高度不应超过 1000 米 (在 1000 米 -4000 米高度范围内, 操作机应降额使用)。 Allowable altitude: not more than 1000m above sea level. 不应有腐蚀性、可燃性、易爆性气体。 No corrosive, flammable or explosive gases.	



* 若去除机械限位, 运动范围可达 -180°/+180°。
If the mechanical limit is removed, the working range can reach -180°/+180°.

外形尺寸及运动范围 Outline dimension and Working range

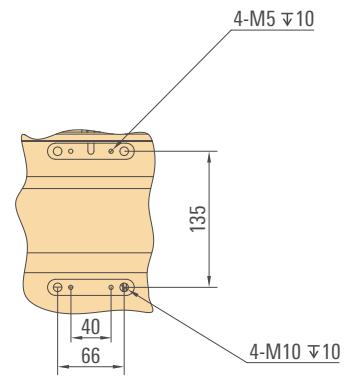
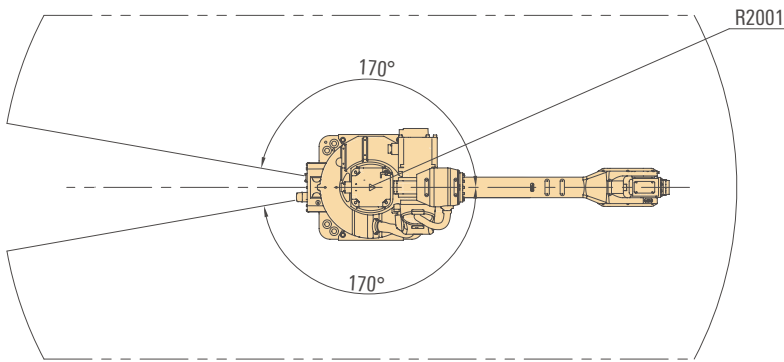
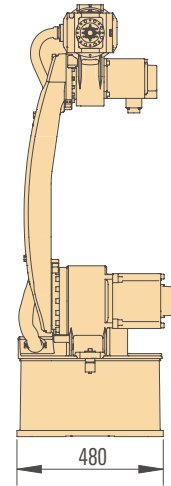
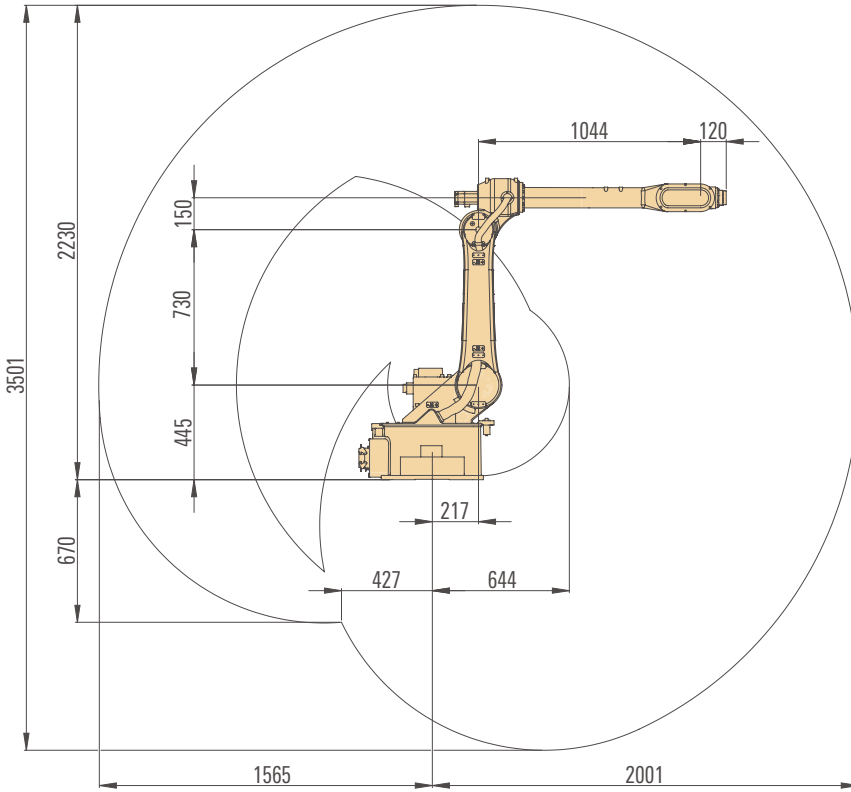

肘部孔位图
Elbow arm

法兰图 Flange drawing

底座安装图 Base installation drawing

