



AIR165-2750

高速度
高精度
高稳定性
汽车行业点焊能手
纤细的手腕

High speed
High precision
High stability
Spot welding manipulator
Slim wrist

- 具有连续点焊短距离快速移位能力, 0.5s 内可完成 50mm 位移的快速运动。

AIR165-2750 is capable of rapid movement over a short distance while continuous spot welding, achieving 50mm displacement within 0.5s.

- 操作机手腕纤细, 非常适于探入到白车身内进行点焊作业。

AIR165-2750 has a slim wrist which is very suitable for spot welding in the body in white.

- 配备了管线包, 使得焊接线缆、软管(水/气)与机器人本体紧密贴合, 有效减少干扰和线缆磨损及飞溅损坏, 十分适于复杂度较高的汽车点焊作业。

AIR165-2750 is equipped with dress package, which makes the welding cable and hose (water/gas) closely attached to the robot body, effectively reduces interference, cable wear and splashing damage, very suitable for automobile spot welding with high complexity.

型号 Type		AIR165-2750
轴数 Axes		6
负载 Payload		165kg
机器人本体 Manipulator	重量 Weight	1200kg
	最大运动范围 Reach	2750mm
定位精度 Positioning accuracy	位置重复定位精度 Position repeatability	±0.1mm
IP 等级 Ingress Protection		IP54 (小臂: IP67) IP54 (Forearm: IP67)
安装方式 Mounting		地装 Floor
运动范围 Working range	轴 1* Axis 1 rotation	-170°/+170°
	轴 2 Axis 2 arm	-60°/+85°
	轴 3 Axis 3 arm	-120°/+155°
	轴 4 Axis 4 wrist	-360°/+360°
	轴 5 Axis 5 bend	-125°/+125°
	轴 6 Axis 6 turn	-360°/+360°
运动速度 Rotation rate	轴 1 Axis 1 rotation	125°/s
	轴 2 Axis 2 arm	113°/s
	轴 3 Axis 3 arm	125°/s
	轴 4 Axis 4 wrist	180°/s
	轴 5 Axis 5 bend	175°/s
	轴 6 Axis 6 turn	280°/s
适用控制柜 Controllers		ARC4-165
安装条件 Mounting conditions	环境温度: 0~45℃ Ambient temperature: 0~45℃ 湿度: 恒温下 95% 以内, 无凝露。 Humidity: not more than 95% at constant temperature without condensation. 允许高度: 操作机正常工作环境的海拔高度不应超过 1000 米 (在 1000 米-4000 米高度范围内, 操作机应降额使用)。 Allowable altitude: not more than 1000m above sea level. 不应有腐蚀性、可燃性、易爆性气体。 No corrosive, flammable or explosive gases.	



* 若去除机械限位, 运动范围可达 -180°/+180°。
If the mechanical limit is removed, the working range can reach -180°/+180°.

外形尺寸及运动范围 Outline dimension and Working range

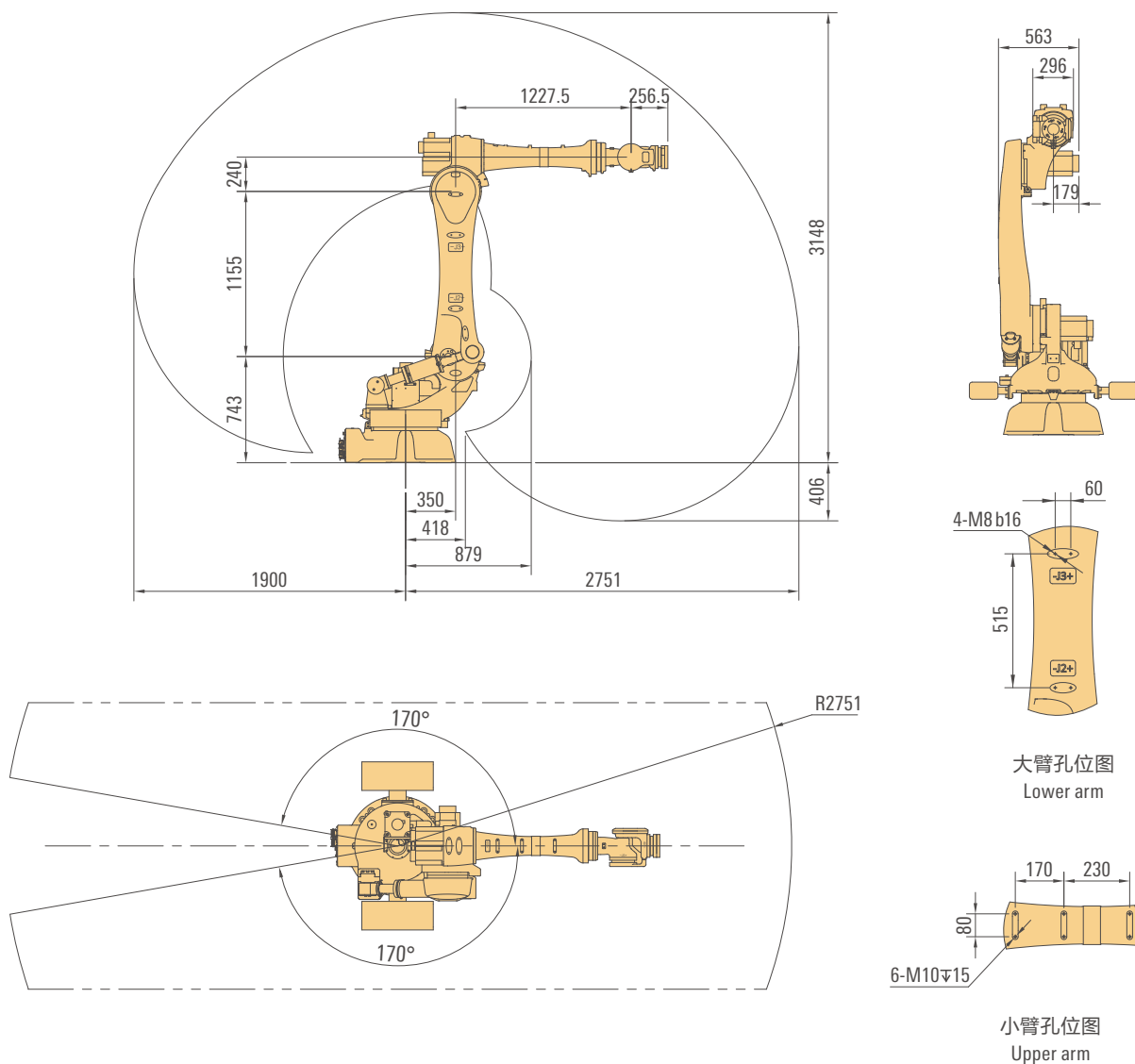

大臂孔位图
Lower arm

小臂孔位图
Upper arm

法兰图 Flange drawing

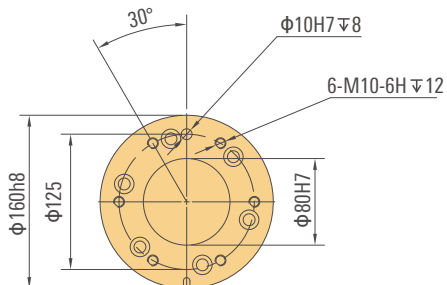

底座安装图 Base installation drawing

