



AIR10-1210

超高速
高精度
高稳定性
高防护等级

High speed
High precision
High stability
IP67

型号 Type		AIR10-1210
轴数 Axes		6
负载 Payload		10kg
机器人本体 Manipulator	重量 Weight	87kg
	最大运动范围 Reach	1211mm
定位精度 Positioning accuracy	位置重复定位精度 Position repeatability	±0.035mm
	IP 等级 Ingress Protection	IP67/ISO5 ^②
安装方式 Mounting		地装 / 壁装 / 吊装 Floor/ wall/ ceiling
运动范围 Working range	轴 1 ^① Axis 1 rotation	-170°/+170°
	轴 2 Axis 2 arm	-100°/+135°
	轴 3 Axis 3 arm	-120°/+156°
	轴 4 Axis 4 wrist	-200°/+200°
	轴 5 Axis 5 bend	-135°/+135°
	轴 6 Axis 6 turn	-360°/+360°
运动速度 Rotation rate	轴 1 Axis 1 rotation	310°/s
	轴 2 Axis 2 arm	320°/s
	轴 3 Axis 3 arm	350°/s
	轴 4 Axis 4 wrist	490°/s
	轴 5 Axis 5 bend	565°/s
	轴 6 Axis 6 turn	815°/s
适用控制柜 Controllers		inCube20
安装条件 Mounting conditions	环境温度：0~45℃ Ambient temperature: 0~45℃ 湿度：恒温下 95% 以内，无凝露。 Humidity: not more than 95% at constant temperature without condensation. 允许高度：操作机正常工作环境的海拔高度不应超过 1000 米（在 1000 米 -4000 米高度范围内，操作机应降额使用）。 Allowable altitude: not more than 1000m above sea level. 不应有腐蚀性、可燃性、易爆性气体。 No corrosive, flammable or explosive gases.	

- 标准门型节拍时间 0.44S。
Standard cycle time 0.44s.
- 内置气路可容纳气量翻倍。
The built-in gas hoses double the air volume.
- 隐藏及分离式设计，避免航插对外挂设备的干扰。
Hidden and separated design avoids interference with external devices brought by the arm connector.
- 线缆固定孔位加深，数量加倍，保证高速运转下线束贴合本体更牢固。
The number and depth of the mounting holes are increased, ensuring that wiring harness keeps adhering to the body firmly at high speed.
- 五轴运动范围高达 ±135°。
The motion range of Axis 5 is up to ± 135°.

机体内配线 • 配管 Integrated dressing

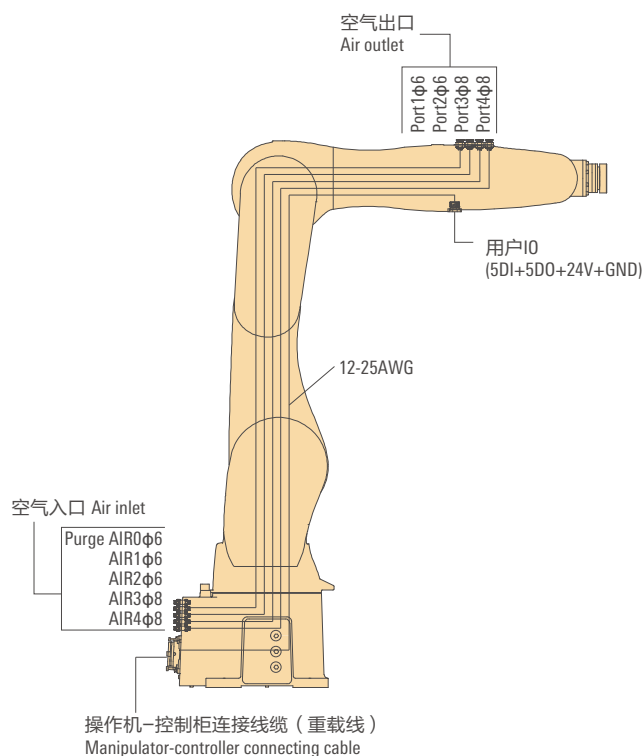

^① 若去除机械限位，运动范围可达 -180°/+180°。
If the mechanical limit is removed, the working range can reach -180°/+180°.

^② 如需 ISO5 版本，请联系销售。
For ISO 5 version, please contact sales.

外形尺寸及运动范围 Outline dimension and Working range

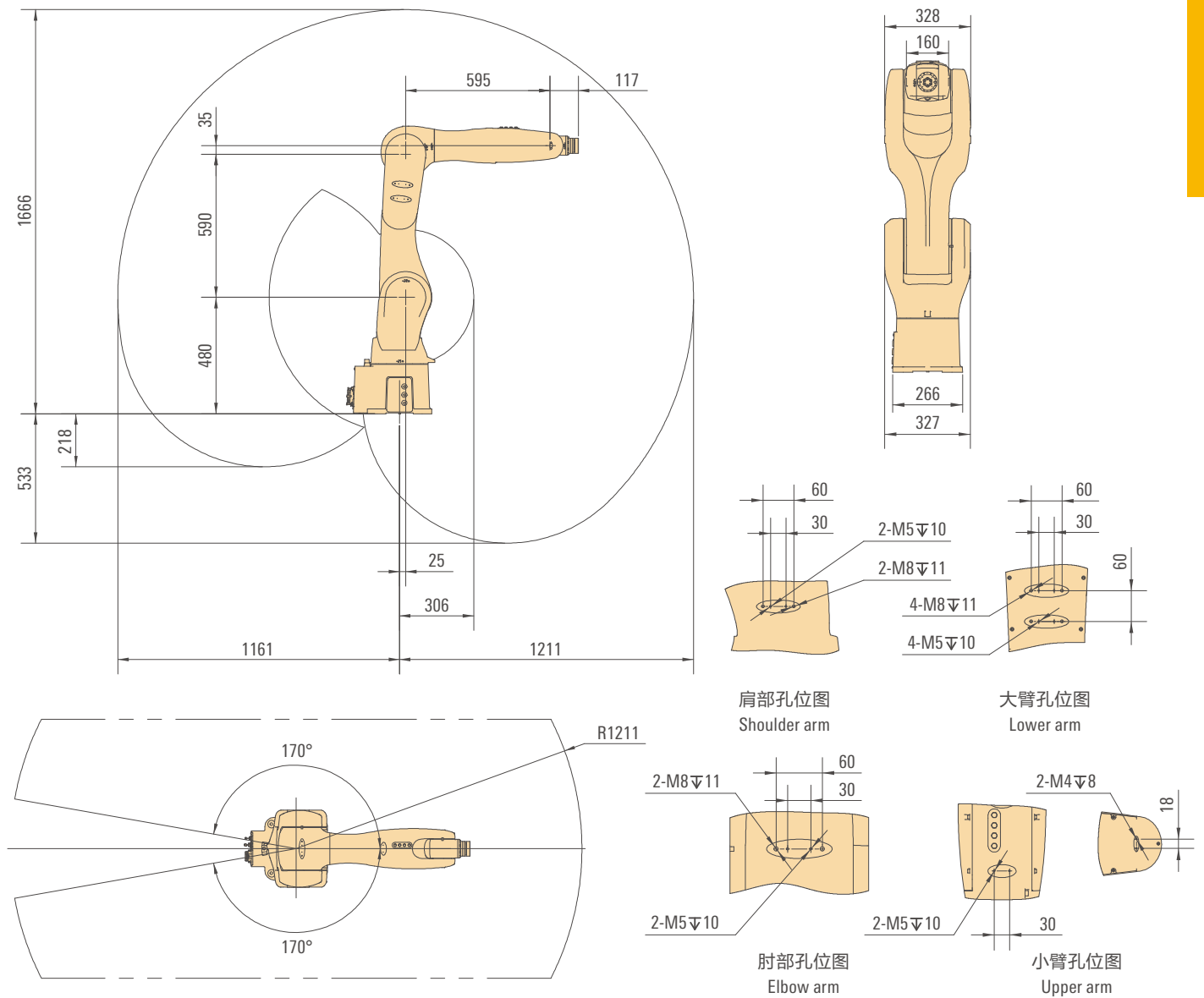

法兰图 Flange drawing

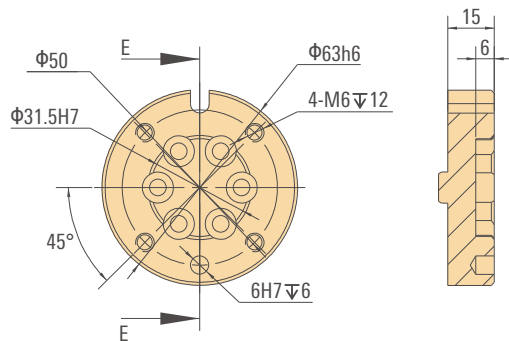

底座安装图 Base installation drawing

