

外形尺寸及运动范围 Outline dimension and Working range

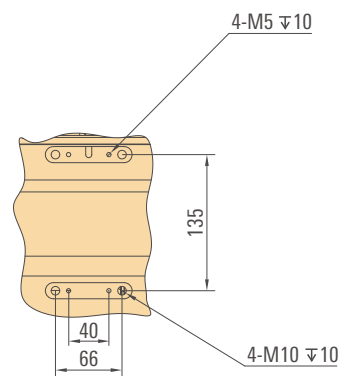

肘部孔位图
Elbow arm

法兰图 Flange drawing

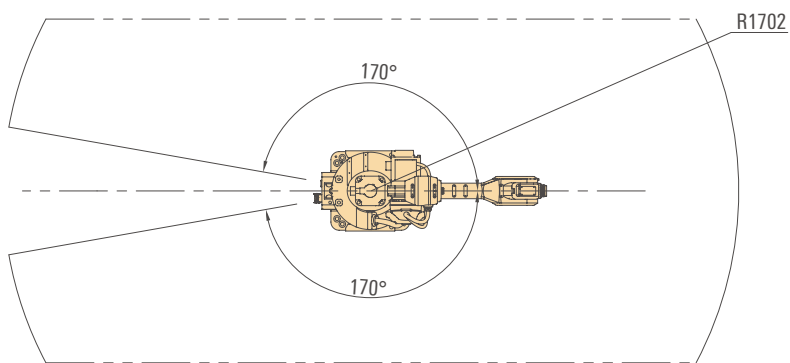
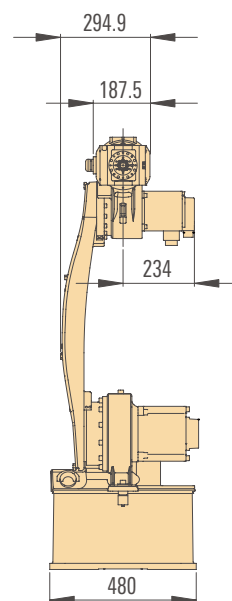
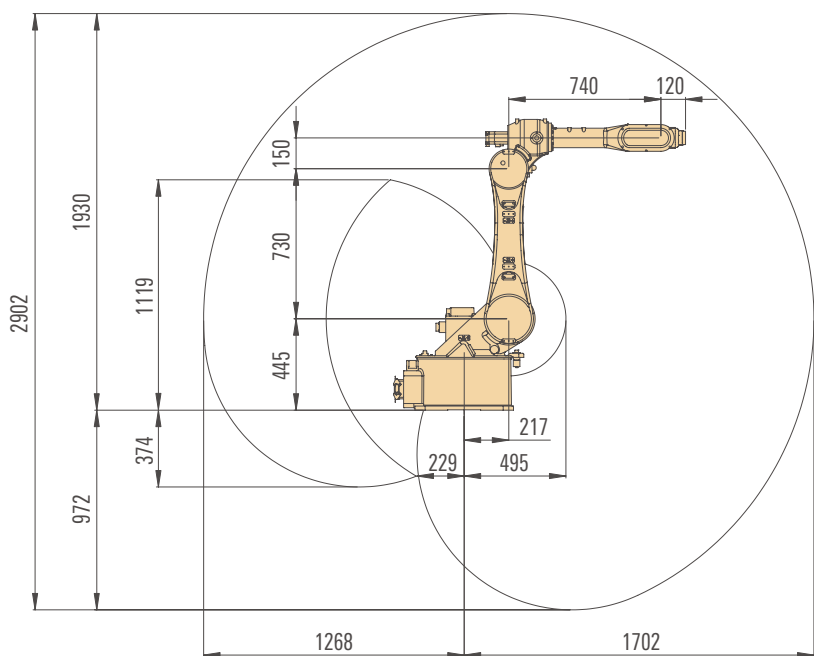
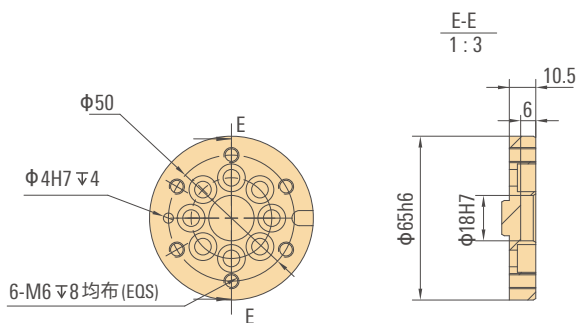

底座安装图 Base installation drawing

